

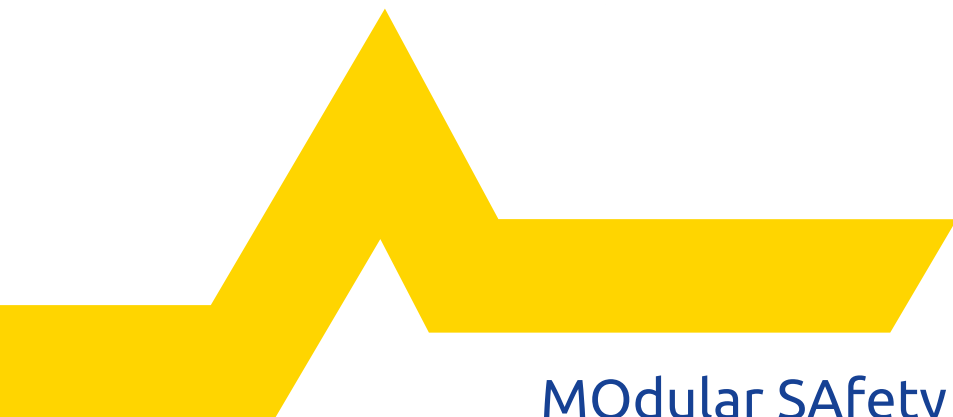

Safety. Detection. Control.



MOSAIC

MODular SAFETY Integrated COntroller

Product catalogue

Issue 1



Mosaic Configuration Memory (MCM)
Removable memory card used to save Mosaic configuration data for subsequent transfers to a new device (without using a PC) or for backup

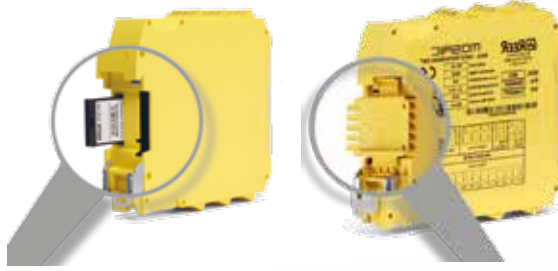

Mosaic Safety Communication (MSC)
Allows communication between the various units through a proprietary high-speed safety bus

MV
Expansion units for safety speed monitoring

MI, MO
Input/Output units.
Up to 128 inputs and 16 OSSD pairs



MOR4, MOR4S8
Safety relay units with configurable outputs

USB Connection
USB 2.0 serial bus for the connection to Mosaic Safety Designer (MSD) software

MR2, MR4
Safety relays units

MB
Expansion unit for connection to the most common industrial Fieldbus systems for diagnostics and data communication

M1 Master unit
Master unit, also usable as a stand-alone device, able to control any other expansion unit



KEY FEATURES

Mosaic is a safety hub able to manage all safety functions of a machinery. **Configurable and scalable**, allows **cost reductions** and **minimal wiring**

Mosaic can manage safety sensors and signals such as:

- Light curtains
- Photocells
- Laser scanners
- Emergency stops
- Electromechanical switches
- Guard-lock safety door switches
- Magnetic switches
- RFID switches
- Safety mats and edges
- Two-hands controls
- Hand grip switches
- Safety switch with guard locking
- Encoders and proximities for safety speed control



ADVANTAGES

Compared to “traditional” electromechanical safety-relays-based safety circuitries, Mosaic has many remarkable advantages, including:

Reducing the number of devices and wiring used and, therefore, the overall size of the project

Speeding-up control panel construction

Providing logic configuration via a quick and easy-to-use software. Machine designers are always able to change configuration logic

Simply adding or removing safety function blocks at any stage of machine design

Is able to check the logic configuration of the application during the designing phase through the validation function and Simulation as well as to test it during the installation through the monitor function

Allows tamper-proof system configurations as:

- detection of tempering attempts through specific tests (i.e. mandatory test of the safety device at machine start-up)
- protection against unauthorized changes to the project through a 2-level password

All logic is configured through a graphic interface. No more laborious wiring is needed as with traditional solutions

A lower number of electromechanical components also means a better Performance Level and, therefore, a higher Safety Level

The project report provides the actual values of PFH_d , DC_{avg} and $MTTF_d$ according to EN 13849-1 and EN 62061

Master unit M1 configurable via the MSD (Mosaic Safety Designer) graphic interface (provided with each Master unit at no extra cost)

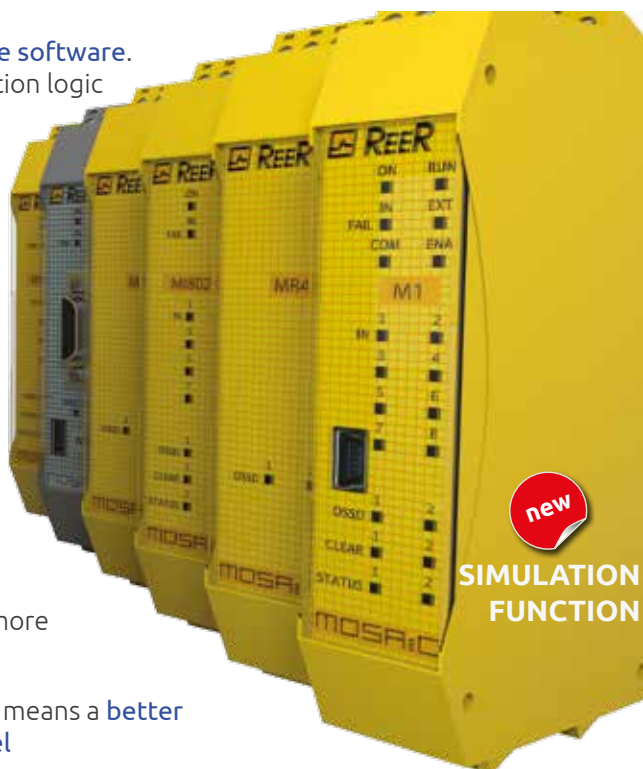

Connect up to 14 expansion

Communication

Speed monitoring

Safety relays

Master unit



MB
Field-bus units
Profibus DP
DeviceNET
CANopen
EtherNET/IP
EtherCAT
PROFINET
Modbus RTU
Modbus TCP/IP
USB

INDUSTRY
4.0
ready

MCT
Interface connection units
Interface module allowing the connection of remote expansions via proprietary MSC bus
MCT1
1 connection interface
MCT2
2 connections interface

MV0/MV1/MV2
Speed monitoring units
Safety speed monitoring (up to PL e) for:
Zero speed control,
Maximum speed control,
Speed range control,
Direction control
MV0
Input for 2 proximity switches
MV1
Input for 1 incremental encoder and 2 proximity switches
MV2
Input for 2 incremental encoders and 2 proximity switches

MOR4/MOR4S8
Safety relay output units
MOR4
4 safety relays with guided contacts
4 NO contacts (250 VAC 6 A)
It is possible to select two different configurations via MSD:
- 4 independent single channel outputs
- 2 dual channel outputs
4 input for Start/Restart interlock and EDM
Single channel LED signaling
MOR4S8
As MOR4, with 8 status outputs (PNP 100 mA)

MR2/MR4
Safety relay output units
MR2
2 safety relays with guided contacts
2 NO + 1 NC contacts (250 VAC 6 A)
1 NC contacts for EDM feedback
MR4
4 safety relays with guided contacts
4 NO + 2 NC contacts (240 VAC 6 A)
2 NC contacts for EDM feedback

M1
Master unit
8 digital inputs
2 input for Start/Restart interlock and EDM
2 pairs OSSD Cat. 4 safety outputs (PNP 400 mA)
2 status outputs (PNP 100 mA)
4 test outputs (for short-circuits monitoring)

units to the M1 Master unit

Additional inputs



MI8/MI16/MI12T8

Input units

MI8

8 digital inputs

4 test outputs (for short-circuits monitoring)

MI16

16 digital inputs

4 test outputs (for short-circuits monitoring)

MI12T8

12 digital inputs

8 test outputs (for short-circuits monitoring)

Can manage up to 4 independent safety mats/edges

Additional outputs



MO2/MO4

Output units

MO2

2 pairs OSSD Cat. 4 safety outputs (PNP 400 mA)

2 input for Start/Restart interlock and EDM

2 status outputs (PNP 100 mA)

MO4

4 pairs OSSD Cat. 4 safety outputs (PNP 400 mA)

4 input for Start/Restart interlock and EDM

4 status outputs (PNP 100 mA)

MO4LHCS8

High current output unit

4 single channels or 2 pairs OSSD Cat. 4 safety outputs (PNP 2,0 A)

4 input for Start/Restart interlock and EDM

8 status outputs (PNP 100 mA)

Additional inputs/outputs



MI8O2

Input/Output unit

8 digital inputs

2 input for Start/Restart interlock and EDM

2 pairs OSSD Cat. 4 safety outputs (PNP 400 mA)

2 status outputs (PNP 100 mA)

4 test outputs (for short-circuits monitoring)

Additional status outputs



MOS8/MOS16

Non-safety output units

MOS 8

8 status outputs (PNP 100 mA)

MOS16

16 status outputs (PNP 100 mA)



- DIGITAL INPUTS
8
- SAFETY OUTPUTS
2
- EDM/RESTART
2
- TEST OUTPUTS
4
- STATUS OUTPUTS
2

M1

MASTER UNIT

Master unit, also usable as a stand-alone device, able to control any other expansion unit. With 8 digital inputs and 2 safety outputs pairs.

APPLICATION EXAMPLE

Standalone: To provide protection for a smaller machinery connecting for example 1 safety light curtain, 1 e-stop, 1 magnetic sensor and 1 two-hand switch.

As Master unit: To control a more complex system providing protection for bigger machineries.

APPROVALS

- 2006/42/EC: "Machine Directive"
- 2004/108/EC: "Electromagnetic Compatibility Directive".
- 2006/95/EC: "Low Voltage Directive"
- EN 61496-1:2013 "Safety of machinery - Electro sensitive protective equipment - General requirements and tests"
- EN 61131-2:2007 "Programmable controllers - Part 2. Equipment requirements and tests"
- EN 61508-1:2010 "Functional safety of electrical / electronic / programmable electronic safety related systems - General requirements"
- EN 61508-2:2010 "Functional safety of electrical / electronic / programmable electronic safety related systems - Requirements for electrical/electronic/programmable electronic safety-related systems"
- EN 61508-3:2010 "Functional safety of electrical / electronic / programmable electronic safety related systems: Software requirements"
- EN 61508-4:2010 "Functional safety of electrical / electronic / programmable electronic safety related systems - Definitions and abbreviations"
- EN 62061:2005 "Safety of machinery - Functional safety of safety-related electrical, electronic and programmable electronic control systems"
- EN ISO 13849-1:2008 "Safety of machinery - Safety-related parts of control systems - Part 1: General principles for design"
- IEC 61784-3:2008 "Industrial communication networks - Profiles - Part 3: Functional safety fieldbuses - General rules and profile definitions"
- UL (C+US) mark for USA and Canada
- ANSI / UL 1998: "Safety Software in Programmable Components"
- The S-Mark carries the same weight in Korea as the CE-Mark does in Europe

Certifications



SAFETY LEVEL

SIL 3

SIL3 - SILCL 3
PL e - Cat. 4

TECHNICAL FEATURES

Digital inputs	8 digital inputs
Safety outputs	2 OSSD pairs - PNP 400 mA output current
EDM	2 inputs for Start/Restart interlock and external device monitoring (EDM)
Status outputs	2 programmable digital signal outputs PNP 100 mA output current
Test outputs	4 test outputs for sensor monitoring
LED signalling	Input/output status and fault diagnostics
Configuration	With PC via USB interface using MSD (Mosaic Safety Designer) software
MSC bus connection	With MSC connector (optional)
MCM	Mosaic Configuration Memory (optional)

ACCESSORIES

MSC Rear Bus connector: necessary to connect the M1 Master unit to any expansion module. As the M1 Master unit can be used as standalone, the bus connector must be ordered separately.

MCM Card (Mosaic Configuration Memory): memory card designed to store the M1 Master unit configuration as a back-up. Can be used to restore the saved configuration onto a new M1 Master unit or to duplicate the current configuration to other M1 Master units.

PART NUMBERS

1100000	M1 Master unit
1100060	MCM - Memory card
1100061	MCS - Rear bus connector
1100062	USB configuration cable (A-mini B, length 1,8 m)
1100079	CPM - Polarizing keys for Mosaic connectors

MI802

INPUT/OUTPUT EXPANSION UNIT

Input/output expansion unit. With 8 digital inputs and 2 safety outputs pairs it doubles the capabilities of an M1 Master unit.

APPLICATION EXAMPLE

To provide more inputs and outputs for a smaller machinery connecting for example extra safety sensors and/or e-stops buttons and to control 2 extra actuators.



- DIGITAL INPUTS
8
- SAFETY OUTPUTS
2
- EDM/RESTART
2
- TEST OUTPUTS
4
- STATUS OUTPUTS
2

TECHNICAL FEATURES

Digital inputs	8 digital inputs
Safety outputs	2 OSSD pairs - PNP 400 mA output current
EDM	2 inputs for Start/Restart interlock and external device monitoring (EDM)
Status outputs	2 programmable digital signal outputs - PNP 100 mA output current
Test outputs	4 test outputs for sensor monitoring
LED signalling	Input/output status and fault diagnostics
Connection to M1	Via MSC connector (included)

PART NUMBERS

1100010	MI802 Expansion unit
1100079	CPM - Polarizing keys for Mosaic connectors

MI8 - MI16

INPUT EXPANSION UNITS

Input expansion units with 8 (MI8) or 16 (MI16) digital inputs increase the number of inputs of an M1 Master unit.

APPLICATION EXAMPLE

To provide more inputs for a smaller machinery connecting for example extra safety sensors and/or e-stops buttons.



- DIGITAL INPUTS
8 (MI8)
16 (MI16)
- TEST OUTPUTS
4

TECHNICAL FEATURES

Digital inputs	8 digital inputs
Test outputs	4 test outputs for sensor monitoring
LED signalling	Input/output status and fault diagnostics
Connection to M1	Via MSC connector (included)

PART NUMBERS

1100020	MI8 Expansion unit
1100021	MI16 Expansion unit
1100079	CPM - Polarizing keys for Mosaic connectors

MI12T8

INPUT EXPANSION UNIT

Input expansion unit for safety mats and edges. With 12 digital inputs and 8 test outputs for sensor monitoring.

APPLICATION EXAMPLE

With 8 test outputs can manage up to 4 independent safety mats or edges. Test output signals are used to monitor overloads and short circuits on input lines.



DIGITAL INPUTS
12

TEST OUTPUTS
8

TECHNICAL FEATURES

Digital inputs	12 digital inputs
Test outputs	8 test outputs for sensor monitoring
LED signalling	Input/output status and fault diagnostics
Connection to M1	Via MSC connector (included)

PART NUMBERS

1100022	MI12T8 Expansion unit
1100079	CPM - Polarizing keys for Mosaic connectors

MO2 - MO4

OUTPUT EXPANSION UNITS

Output expansion units with 2 (MO2) or 4 (MO4) safety outputs pairs increase the number of safety outputs of an M1 Master unit.

APPLICATION EXAMPLE

To provide more safety outputs in machine where different actuators need to be controlled. For example automatic packaging machines, etc.



SAFETY OUTPUTS
2 (MO2)
4 (MO4)

EDM/RESTART
2 (MO2)
4 (MO4)

STATUS OUTPUTS
2 (MO2)
4 (MO4)

TECHNICAL FEATURES

Safety outputs	MO2 - 2 OSSD pairs - PNP 400mA output current MO4 - 4 OSSD pairs - PNP 400mA output current
EDM	MO2 - 2 inputs for Start/Restart interlock and external device monitoring (EDM) MO4 - 4 inputs for Start/Restart interlock and external device monitoring (EDM)
Status outputs	MO2 - 2 programmable digital signal outputs - PNP 100 mA output current MO4 - 4 programmable digital signal outputs - PNP 100 mA output current
LED signalling	Input/output status and fault diagnostics
Connection to M1	Via MSC connector (included)

PART NUMBERS

1100030	MO2 Expansion unit
1100031	MO4 Expansion unit
1100079	CPM - Polarizing keys for Mosaic connectors

MO4LHCS8 new

HIGH CURRENT OUTPUT EXPANSION UNIT

Output expansion unit with 4 high current safety outputs (PNP 2,0 A per channel, 8 A in total), 4 relative inputs for external feedback contacts (EDM) and 8 status output.

APPLICATION EXAMPLE

To provide 2 different high current output configurations (configurable with MSD configuration software)

- Two double independent channels (2 safety outputs per channel with 2 feedback inputs)
- Four single independent channels (1 safety output per channel with 4 feedback inputs)

The module provide 8 programmable signal outputs.



SAFETY OUTPUTS
4 single channels or
2 double channels

EDM/RESTART
4

STATUS OUTPUTS
8

TECHNICAL FEATURES

Safety outputs	4 single channels (or 2 double channels) Solid state safety outputs PNP active high
EDM	4 inputs for Start/Restart interlock and external device monitoring (EDM)
Output current	2A max per channel (total current 8A)
Status outputs	PNP 100 mA output current
LED signalling	Output status and fault diagnostics
Connection to M1	Via MSC connector (included)

PART NUMBERS

1100032	MO4LHCS8 Expansion unit
1100079	CPM - Polarizing keys for Mosaic connectors

MR2 - MR4

SAFETY RELAY UNITS

Output expansion units provide 2 (MR2) or 4 (MR4) safety relays outputs with guided contacts connectable to 2 or 4 independent OSSD pairs. These units can also be used separately from the Mosaic system.

APPLICATION EXAMPLE

To provide 2 or 4 guided contact safety relay in applications where there is the need to cut the actuators power supply. Each NO contact is interrupted twice by the integrated safety relays.



SAFETY RELAY
2 (MR2)
4 (MR4)

TECHNICAL FEATURES

Safety relays	MR2 - 2 safety relays with 6 A 250 VAC guided contacts: 2 NO + 1 NC for EDM feedback MR4 - 4 safety relays with 6 A 250 VAC guided contacts: 4 NO + 2 NC for EDM feedback
LED signalling	OSSD output status (input in MRx)
Connection to M1	The MR2 and MR4 expansion units do not require MSC as they are wired directly to the selected OSSD

PART NUMBERS

1100040	MR2 Expansion unit
1100041	MR4 Expansion unit
1100079	CPM - Polarizing keys for Mosaic connectors

MOR4

SAFETY RELAY WITH CONFIGURABLE OUTPUTS UNITS

Output expansion units provide 4 configurable safety relays with guided contacts.

APPLICATION EXAMPLE

To provide 4 configurable guided contact safety relay. It allows to select the safety category via MSD:

- Safety Cat. 1: 4 independent single channel outputs
- Safety Cat. 2: 4 independent single channel outputs with OTE (Output Test Equipment)
- Safety Cat. 4: 2 independent double channels outputs



SAFETY RELAY
4
EDM/RESTART
4

TECHNICAL FEATURES

Safety relays	4 safety relays with 6 A 250 VAC guided contacts
EDM	4 inputs for Start/Restart interlock and external device monitoring (EDM)
LED signalling	Output status and fault diagnostics
Connection to M1	Via MSC connector (included). Do not use M1 OSSDs to drive relays

PART NUMBERS

1100042	MOR4 Expansion unit
1100079	CPM - Polarizing keys for Mosaic connectors

MOR4S8

SAFETY RELAY WITH CONFIGURABLE OUTPUTS UNITS AND 8 SIGNAL OUTPUTS

Output expansion units provide 4 configurable safety relays with guided contacts.

APPLICATION EXAMPLE

To provide 4 configurable guided contact safety relay. It allows to select the safety category via MSD:

- Safety Cat. 1: 4 independent single channel outputs
- Safety Cat. 2: 4 independent single channel outputs with OTE (Output Test Equipment)
- Safety Cat. 4: 2 independent double channels outputs



SAFETY RELAY
4
EDM/RESTART
4
STATUS OUTPUTS
8

TECHNICAL FEATURES

Safety relays	4 safety relays with 6 A 250 VAC guided contacts
EDM	4 inputs for Start/Restart interlock and external device monitoring (EDM)
LED signalling	Output status and fault diagnostics
Connection to M1	Via MSC connector (included). Do not use M1 OSSDs to drive relays

PART NUMBERS

1100043	MOR4S8 Expansion unit
1100079	CPM - Polarizing keys for Mosaic connectors



INPUT MV0 2 Proximities	INPUT MV1 1 Encoder 1 or 2 Proximities	INPUT MV2 1 or 2 Encoders 1 or 2 Proximities
AXIS MV0 2	AXIS MV1 2	AXIS MV2 2

RJ-45 (1 for MV1, 2 for MV2) connectors for encoders and terminal blocks for proximity switches.

Max. input frequency for encoders: up to 500 KHz (300 KHz for HTL encoder).

Max. input frequency for proximity switches: up to 5 KHz.

The MV2 module includes two configurable logical outputs and is therefore able to control up to two independent axis (configuration via MSD).

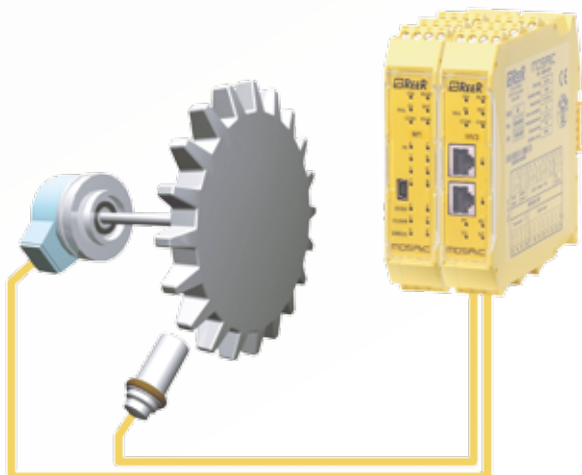

MV0 - MV1 - MV2

SAFETY SPEED MONITORING UNITS

Safety speed monitoring (up to PL e) for: zero speed control, max. speed, speed range and direction control.

APPLICATION EXAMPLE

Any application requiring speed monitoring for a hazardous tool. See relevant application example on page 34. Maintenance speed control in rail dependent storage and retrieval equipment applications.

TECHNICAL FEATURES

Digital inputs	MV0 - Input for 2 PNP/NPN proximity switches MV1 - Input for 1 incremental encoder (TTL, HTL or SIN/COS) and 1 or 2 PNP/NPN proximity switches MV2 - Input for 1 or 2 incremental encoder (TTL, HTL or SIN/COS) and 1 or 2 PNP/NPN proximity switches
Speed thresholds	Up to 4 logically selectable speed thresholds (freely configurable via MSD) for each logical output (axis)
LED signalling	Input/output status and fault diagnostics
Connection to M1	Via MSC connector (included)

ACCESSORIES

SAFECODER - Safety Sin/Cos incremental encoder. See page 15

PART NUMBERS

1100077	MV0 - Proximities switch expansion module
1100070	MV1T - 1 TTL incremental encoder + 1 or 2 PNP/NPN proximity switches expansion module
1100086	MV1TB - 1 TTL incremental encoder (24 VDC) + 1 or 2 PNP/NPN proximity switches expansion module
1100071	MV1H - 1 HTL incremental encoder + 1 or 2 PNP/NPN proximity switches expansion module
1100072	MV1S - 1 SIN/COS incremental encoder + 1 or 2 PNP/NPN proximity switches expansion module
1100073	MV2T - 1 or 2 TTL incremental encoders + 1 or 2 PNP/NPN proximity switches expansion module
1100087	MV2TB - 1 or 2 TTL incremental encoders (24 VDC) + 1 or 2 PNP/NPN proximity switches expansion module
1100074	MV2H - 1 or 2 HTL incremental encoders + 1 or 2 PNP/NPN proximity switches expansion module
1100076	MV2S - 1 or 2 SIN/COS incremental encoders + 1 or 2 PNP/NPN proximity switches expansion module
1100079	CPM - Polarizing keys for Mosaic controller connectors

MCT1 - MCT2

REMOTE INTERFACE UNITS

Interface module allowing the connection of remote expansions units via the MSC bus.

APPLICATION EXAMPLE

Ideal solution for the interconnection of the safety functions of more machineries on a single production line. MCT1 and MCT2 are not shown in MSD configuration software as do not count as expansions.



CONNECTION INTERFACE
1 (MCT1)
2 (MCT2)

TECHNICAL FEATURES

Connection	MCT1 - 1 connection: 1 input or 1 output to be placed at the beginning or at the end of the network MCT2 - 2 connections: 1 input and 1 output
Cable	Shielded RS 485 serial interface compatible cable (4 wires + shield) via the connector block. We recommend the use of Reer's cables for a correct operation of the system
Total distance	Up to 50 m for each connection (total distance up to 250 m). Max. 5 MCT expansions units
LED signalling	Module status and fault diagnostics
Connection to M1	Via MSC connector (included)

PART NUMBERS

1100058	MCT1 Expansion unit
1100057	MCT2 Expansion unit
1100063	MCT25 - Serial cable for MSC bus transfer 25 m
1100064	MCT50 - Serial cable for MSC bus transfer 50 m
1100065	MCT100 - Serial cable for MSC bus transfer 100 m

HM1

DISPLAY UNIT

Alphanumeric display. It displays the messages programmed using the HSD software.



APPLICATION EXAMPLE

Used in control panels to display status messages as diagnostic or operation functions of the safety system. Can be also used to display other functioning messages of the machine or the plant.

TECHNICAL FEATURES

Display	Green display LCD 2x16
Ports	2 configurable RS 485 serial ports USB port for messages on display programming
Inputs	4 inputs for the connection with Mosaic: 2 synchronous serial ports (clock + data) or 4 asynchronous serial ports (data)

HM1 can be connected to Mosaic 3 ways:

Wired to a status output connected to the serial operator, asynchronous serial connection
Max 32 status displayed.

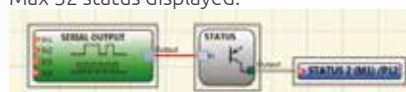

Wired to 2 status outputs connected to the serial operator, synchronous serial connection
Max 16 status displayed.



Wired to the serial MBx module via RS 485 serial port, all I/O statuses and diagnostic displayed.

PART NUMBERS

1100090	HM1 Expansion unit
1100062	USB cable A-mini B, length 1,8 m

MBs

FIELD-BUS EXPANSION UNITS

Expansion unit for connection to the most common industrial Field-bus systems for diagnostics and data communication.

APPLICATION EXAMPLE

In all applications where it is required to communicate between the machine's safety system and the PLC control.



- MBP - Profibus DPM
- MBD - DeviceNET
- MBC - CANopen
- MBEC - EtherCAT
- MBEI - EtherNET/IP
- MBEP - PROFINET
- MBU - Universal Serial Bus
- MBMR - Modbus RTU
- MBEM - Modbus TCP/IP

TECHNICAL FEATURES

Ports	RS 485 serial ports for I/O Bus expansion USB port for configuration
Connection to M1	Via MSC connector (included)

PART NUMBERS

1100050	MBP Profibus DP expansion module
1100051	MBD DeviceNET expansion module
1100052	MBC CANopen expansion module
1100053	MBEC EtherCAT expansion module
1100054	MBEI EtherNET/IP expansion module
1100085	MBEI2B EtherNET/IP expansion module (with two connectors)
1100055	MBEP PROFINET expansion module
1100056	MBU Universal Serial Bus expansion module
1100082	MBMR Modbus RTU expansion module
1100083	MBEM Modbus TCP/IP expansion module

MOS8 - MOS16

AUTOMATION OUTPUT EXPANSION UNITS

Non-safety output expansion units.

APPLICATION EXAMPLE

Modules for automation where non-safety outputs are required. In this way the Mosaic controller can also be used as a PLC for automation.



- STATUS OUTPUTS
- 8 (MOS8)
- 16 (MOS16)

TECHNICAL FEATURES

Status outputs	MOS8 - 8 programmable digital signal outputs - PNP 100 mA output current MOS16 - 16 programmable digital signal outputs - PNP 100 mA output current
LED signalling	Output status and fault diagnostics
Connection to M1	Via MSC connector (included)

PART NUMBERS

1100091	MOS8 Expansion unit
1100092	MOS16 Expansion unit

TECHNICAL FEATURES SUMMARY

Module	M1	MI802	MI8 MI16	MI12T8	MO2 MO4	MO4LHCS8	MR2 MR4	MOR4 MOR4 S8	MV	MCT1 MCT2	MBx	MOS8 MOS16
Description	Master unit	Input/Output unit	Input units	Input unit	Output units	High Current Safety Outputs units	Guided contact relay output units	Safety relay configurable output units	Safety speed monitoring units	Remote interface units	Field bus units	Automation units
USB	yes	-	-	-	-	-	-	-	-	-	yes	-
MCM	Optional	-	-	-	-	-	-	-	-	-	-	-
Connection with MSC bus	yes	yes	yes	yes	yes	yes	-	yes	yes	yes	yes	yes
MSC connector provided	no	yes	yes	yes	yes	yes	-	yes	yes	yes	yes	yes
Safety level	SIL 3 – SILCL 3 according to IEC 61508 - IEC 62061 / PL e – Cat. 4 according to ISO 13849-1											
Safety inputs	8	8	8-16	12	-	-	-	-	2-4	-	-	-
Safety outputs (OSSD)	2 pairs PNP 400 mA	-	-	-	2-4 pairs PNP-400 mA	4 or 2 PNP 2A max	-	-	-	-	-	-
Programmable status outputs	2 PNP 100 mA	-	-	-	2-4 PNP 100 mA	-	-	MOR4 S8 8 PNP 100 mA	-	-	-	8-16 PNP 100 mA
Test outputs	4	4	4	8	-	8	-	-	-	-	-	-
Safety relay outputs	-	-	-	-	-	-	2 NO + 1 NC 4 NO + 2 NC 6 A 250 VAC	4 NO single 6 A 250 VAC or 2 NO pairs 6 A 250 VAC	-	-	-	-
Start/Restart inputs and External Device Monitoring	2	2	-	-	2-4	4	-	4	-	-	-	-
Led signalling	Input/output status and fault diagnostics					Output status			Input status and fault diag.	Output status	Fault diag.	Output status and fault diag.
Power supply (VDC)							24 ± 20%					
Connections	Removable terminal blocks, screw contacts											
Operating temperature	-10 to 55 °C											
Storage temperature	-20 to 85 °C											
Protection rating	IP20 for housing / IP 2X for terminal block											
Fastening	Rail fastening according to EN 50022-35 standard											
Dimension HxWxD (mm)	99 x 22,5 x 114											

- Compact design: single module dimensions 22.5 x 99 x 114.5 mm
- Removable terminal blocks, screw contacts
- Input/Output connectors: 24 x 22.5 mm, 6 removable terminal blocks, screw contact
- Possible connection with Reer MSC rear bus for connection with other expansion modules (not included)

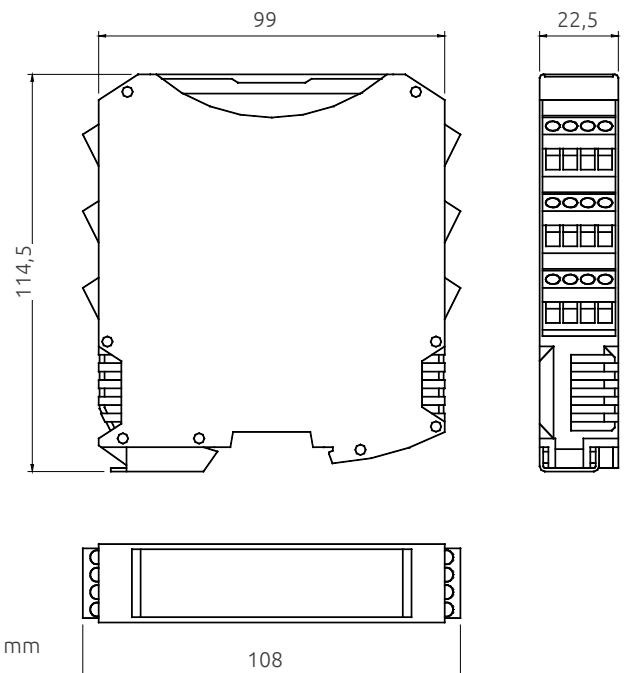

Dimensions: mm



Shaft version



Hollow shaft version

APPROVALS

- 2006/42/EC "Machinery Directive"
- 2004/108/EC "Electromagnetic Compatibility (EMC)"
- EN ISO 13849-1 "Safety of machinery: Safety-related parts of control systems. Part 1: General principles for design"
- EN ISO 13849-2 "Safety of machinery: Safety-related parts of control systems. Part 2: Validation"
- IEC 61508 "Functional safety of electrical, electronic and programmable electronic safety-related systems"
- EN ISO 61800-5-2 "Adjustable speed electrical power drive systems". Part 5-2 Safety requirements - Functional
- UL (C+US) mark for USA and Canada
- BGIA - Institute for Occupational Safety and Health - Germany

Certifications



SAFETY LEVEL

SIL 3

SIL3 - SILCL 3
PL e - Cat. 4

SAFECODER

Safety Sin/Cos incremental encoder, together with Mosaic, comprise a SIL 3 certified safety function for speed monitoring. Available in two models: Shaft or Hollow shaft versions.

APPLICATION EXAMPLE

Any applications requiring speed monitoring of a rotating axis. See the application example [on page 34](#).

Features a robust and reliable interface and the ability to handle high mechanical loads.

TECHNICAL FEATURES

Shaft type	Hollow shaft version Ø 12 mm Shaft version Ø 10 mm with flat
Fastening	Safety-Lock™ Allow high rotational speed and high shaft load capacity
Protection rate	Housing and flange side IP67, shaft IP65 (optional IP67)
Immunity to interference	Shock and vibration resistant Insensitive to strong magnetic fields
Resolution	2048 pulse rate
Power supply	SC3 24D2048R - 24 VDC SC3 05D2048R - 5 VDC SC3 24B2048R - 24 VDC SC3 05B2048R - 5 VDC
Connector	Radial M12

PART NUMBERS

1100102	SC3 24D2048R - 24 V Hollow Shaft version Ø 12 mm
1100103	SC3 05D2048R - 5 V Hollow Shaft version Ø 12 mm
1100104	SC3 24B2048R - 24 V Shaft version Ø 10 mm with flat
1100105	SC3 05B2048R - 5 V Shaft version Ø 10 mm with flat
1330930	C8D5 SH - M12 straight connector, 8 poles, pre-wired shielded cable 5 m
1330931	C8D10 SH - M12 straight connector, 8 poles, pre-wired shielded cable 10 m
1330932	C8D15 SH - M12 straight connector, 8 poles, pre-wired shielded cable 15 m
1330933	C8D95 SH - M12 90° angled connector, 8 poles, pre-wired shielded cable 5 m
1330934	C8D910 SH - M12 90° angled connector, 8 poles, pre-wired shielded cable 10 m
1330935	C8D915 SH - M12 90° angled connector, 8 poles, pre-wired shielded cable 15 m

NOTE: cable supplied with M12 8-pole connector at one end only. The other side must be cut off at correct length and crimped with RJ45 connector (not included).

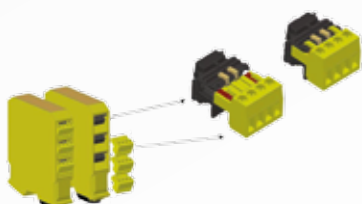
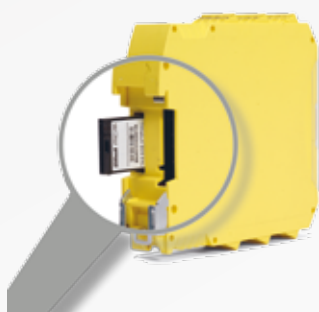

MCM

MOSAIC CONFIGURATION MEMORY

Models	Ordering codes	Description
MCM	1100060	Mosaic Configuration Memory – Memory Card

MSC

MOSAIC SAFETY COMMUNICATION

Models	Ordering codes	Description
MSC	1100061	Mosaic Safety Communication – Connector

CSU

USB CONFIGURATION CABLE

Models	Ordering codes	Description
CSU	1100062	USB A cable – mini B, length 1,8 m

CPM

POLARIZING KEYS

Model	Ordering code	Description
CPM	1100079	Polarizing keys for Mosaic controller connectors

MCT

SERIAL CABLE FOR MSC BUS TRANSFER

Models	Ordering codes	Description
MC25	1100063	MCT serial cable for MSC bus transfer 25 m
MC50	1100064	MCT serial cable for MSC bus transfer 50 m
MC100	1100065	MCT serial cable for MSC bus transfer 100 m

MPD







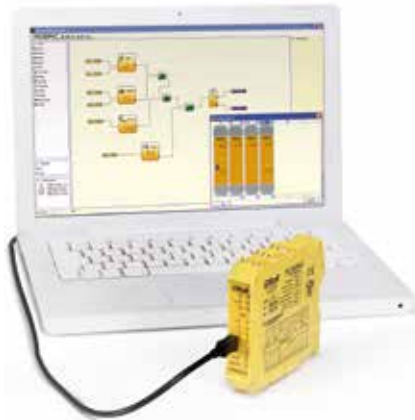

PULL-DOWN ADAPTER

Models	Ordering codes	Description
MPD	1350150	Pull-down resistor
Each kit MPD contains 2 adapters		

CONFIGURATION SOFTWARE

Mosaic M1 is equipped with a 2.0 USB mini interface for connection to a Personal Computer where MSD software is installed.



-  Drag&Drop
-  User-friendly
-  Real-time monitor
-  Design validation
-  Simulation 
-  Security password
-  Reports and log files
-  Project information

“Drag&Drop” configuration of all safety functions.

Functional validation of design.

Real-time I/O monitoring.

Project report with the following information:

- Project name
- Mosaic: Configuration
- Mosaic: Safety Information (PFHd, MTTFd, DCavg)
- Resources used



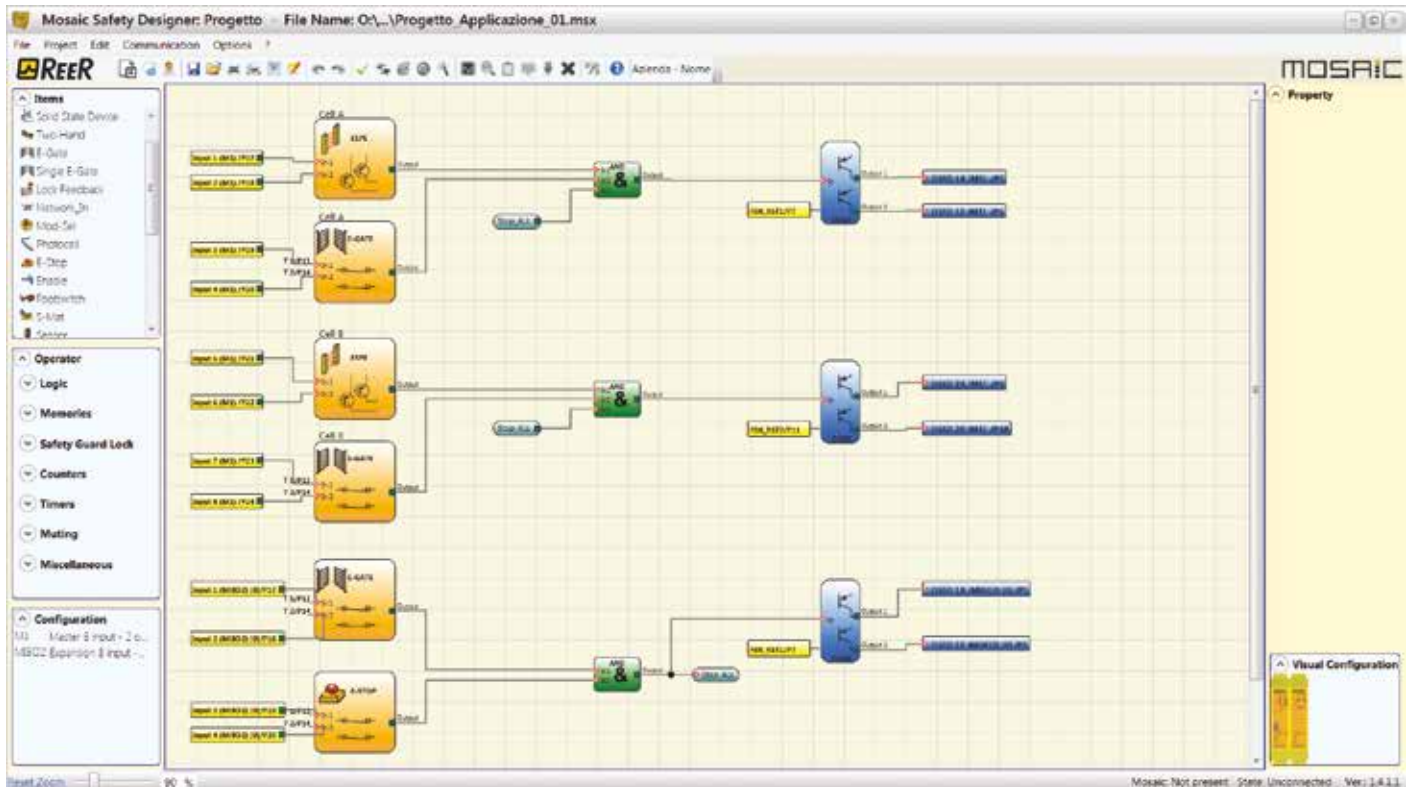

2-level passwords management for the prevention of unauthorised accesses and therefore of incidental modifications or tampering of the system configuration.

Log File with project date of creation and related checksum (CRC 4-digit hexadecimal identification) is stored in the M1 module.

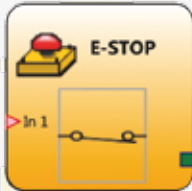
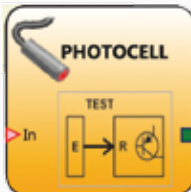
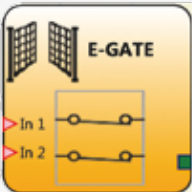
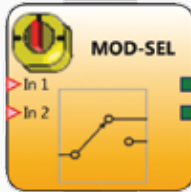

MAIN FUNCTIONAL BLOCKS

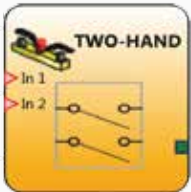
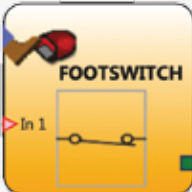
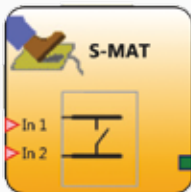
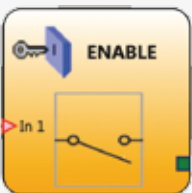
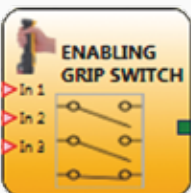
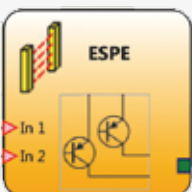
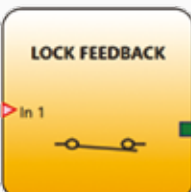
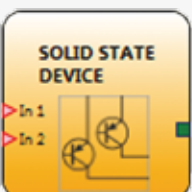
Input objects

	<p>E-stop (emergency stop)</p> <p>Configurable for: 1 NC or 2 NC inputs</p>		<p>Photocell (Type 2 safety photocell)</p> <p>Input for photocells that need external controller. Specific output test is required</p>
	<p>Single E-gate (safety gate device) E-gate (safety gate device)</p> <p>Configurable for: 2 NC or 1 NC + 1NO inputs</p> <p>More info: Property window on page 23</p>		<p>Mod-Sel (safety selector)</p> <p>Configurable for: 2, 3 or 4 position selectors inputs. Specific output test is not required</p>
	<p>Testable Safety Device (for any type of electromechanical sensors)</p> <p>Configurable for: 1 NC, 1 NO, 2 NC or 1 NC + 1 NO inputs</p>		<p>Two-Hand (bi-manual control)</p> <p>Configurable for: 2 NO (EN 574 III A) or 2 NO + 2 NC (EN 574 III C) inputs</p>
	<p>Footswitch (safety pedal)</p> <p>Configurable for: 1 NC, 1 NO, 2 NC or 1 NO + 1 NC inputs</p>		<p>S-Mat (safety mat or safety edge)</p> <p>4 wires technology. 2 inputs Specific output test is required on 2 wires</p>
	<p>Enable (enable key)</p> <p>Configurable for: 1 NO or 2 NO inputs</p>		<p>Enable Grip Switch</p> <p>Configurable for 2 NC or 2 NO + 1 NC inputs</p>
	<p>ESPE (optoelectronic safety light curtain / laser scanner)</p> <p>Safety optoelectronics sensors with static OSSD, self-controlled output Dual channel inputs</p> <p>More info: Automatic or Manual Reset on page 23</p>		<p>Lock Feedback</p> <p>It verifies the lock status of the Guard Lock device for mobile guard or safety gate. More info: Safety Guard Lock operator on page 21</p> <p>In the case where the inputs indicate that the guard is locked the Output will be 1 (TRUE). Otherwise the output is 0 (FALSE)</p>
	<p>Solid State Device</p> <p>Generic safety sensors with static OSSD self-controlled outputs Dual channel inputs</p>		<p>Network_In</p> <p>This input must be used in case of connection between Mosaic OSSD output and the input of another Mosaic to realize a network. More info: Network_In on page 23</p>

Input objects

	<p>Switch</p> <p>Input for non safety switches or non safety signals. E.g.: restart button, position switch, enable signals etc.</p>		<p>Sensor</p> <p>Input for non safety sensors or non safety signals. E.g.: Muting sensors, enable signals etc.</p>
	<p>Fixed input</p> <p>Input fixed to logic level 0 (Low) Input fixed to logic level 1 (High)</p>		<p>Fieldbus input</p> <p>Allows to receive signals (up to 8 bits) from the machine control unit via the field-bus module. The signal is connected directly into the diagrams without using any input block. Warning: FIELDBUS inputs are not a safety signals</p>

Speed monitoring objects

	<p>Stand Still</p> <p>Check that the speed is zero or not greater than the values set</p>		<p>Stand Still and Speed Control</p> <p>Check that the speed does not exceed the values set for both the max. speed and zero speed</p>
	<p>Speed Control</p> <p>Check that the speed is not greater than the values set</p>		<p>Window Speed Control</p> <p>Check that the speed is not lower or higher than the values set</p>

Output objects

	<p>OSSD (category 4 safety outputs)</p> <p>PNP safety static outputs (dual channel, 400 mA). The 2 outputs cannot operate independently</p>		<p>Relay</p> <p>The Output relay is a NO relay output. Relay outputs are closed when the input is equal to 1 (TRUE), otherwise they are open (FALSE)</p>
	<p>Status (signal output)</p> <p>PNP static outputs (single channel, 100 mA). Can be connected to any point in the project</p>		<p>Fieldbus Probe Output</p> <p>Allows to send signals (up to 16 bits) to the machine control unit via the field-bus module</p> <p>The signal is connected directly into the diagrams without using any output block</p>
	<p>Serial Output</p> <p>It makes possible the transmission of information status to a PLC or HM1 without the need to use fieldbus modules. The Serial Output operator outputs the status of up to 8 inputs, serializing the information. Max. number of operators: 4 - total 32 information status</p> <p>The serial line can be: Synchronous (1 clock + 1 data output) Asynchronous (1 Manchester coding data output). For a typical application sample, see HM1 on page 12</p>		

Comments

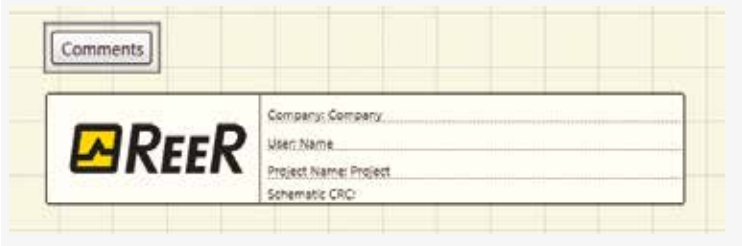

Comments and Title

Add comments to your projects and sign it with a dedicated title box

Logical operators - Up to 64 logical operator can be used

	<p>AND</p> <p>Logical AND returns an output of 1 (TRUE) if all the inputs are 1 (TRUE)</p>		<p>NAND</p> <p>Logical NAND returns an output of 0 (FALSE) if all the inputs are 1 (TRUE)</p>
	<p>NOT</p> <p>Logical NOT inverts the logical status of the input</p>		<p>OR</p> <p>Logical OR returns an output of 1 (TRUE) if at least one of the inputs is 1 (TRUE)</p>
	<p>NOR</p> <p>Logical NOR returns an output of 0 (FALSE) if at least one of the inputs is 1 (TRUE)</p>		<p>XOR</p> <p>Logical XOR returns an output 0 (FALSE) if the input's number at 1 (TRUE) is even or the inputs are all 0 (FALSE)</p>
	<p>XNOR</p> <p>Logical XNOR returns an output 1 (TRUE) if the input's number at 1 (TRUE) is even or the inputs are all 0 (FALSE)</p>		<p>Multiplexer</p> <p>Logical Multiplexer forwards the signal of the inputs to the output according to the SEL selection. If the SEL 1÷SEL4 have only one bit set, the selected In n is connected to the Output.</p> <p>If the SEL inputs are: more than one = 1 TRUE) none = 1 (TRUE)</p> <p>The output is set to 0 (FALSE) independently from the In n values</p>
	<p>Logical Macro</p> <p>Groupings can be created with a maximum of three operators of different types for a total of max. 8 inputs This allows to increase the maximum number of operators used</p>		



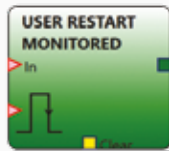
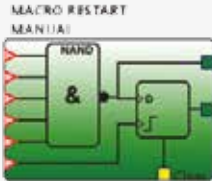
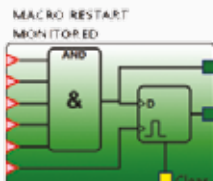

Memory operators

	<p>D Flip-Flop</p> <p>The D Flip-Flop operator saves the previously set status on output Q</p>		<p>User Restart Manual</p> <p>The User Restart Manual operator saves the restart signal according to the Inputs: In, Rising edge input and Clear</p>
	<p>SR Flip-Flop</p> <p>SR Flip-Flop operator brings output Q at 1 with Set, 0 with Reset</p>		

Memory operators

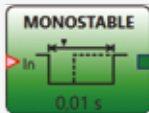
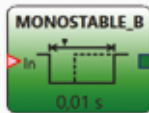
	<p>T Flip-Flop</p> <p>This operator switches the Q output at each rising edge of the T input (Toggle)</p>		<p>User Restart Monitored</p> <p>The User Restart Monitored operator is used to save the restart signal according to the inputs</p>
	<p>Macro Restart Manual</p> <p>Used to combine a logic gate chosen by the user with the Restart Manual functional block User Restart Manual</p>		<p>Macro Restart Monitored</p> <p>Used to combine a logic gate chosen by the user with the Restart Manual functional block User Restart Monitored</p>

Timer operators

	<p>Monostable</p> <p>The Monostable operator generates a level 1 (TRUE) output activated by the rising edge of the input and remains in this condition for the set time</p>		<p>Monostable B</p> <p>This operator generates a level 1 (TRUE) output activated by the rising/falling edge of the input and remains in this condition for the set time</p>
	<p>Passing Make Contact</p> <p>In the Passing Make Contact operator the output follows the signal on the input. However, if this is 1 (TRUE) for longer than the set time, the output changes to 0 (FALSE). When there is an input falling edge, the timer is cleared</p>		<p>Delay</p> <p>Delay operator applies a delay to a signal by setting the output to 1 (TRUE) after the set time, against a change in the level of the input signal</p>
	<p>Delay line</p> <p>When the signal IN is moved to 0 logic level, this operator inserts a delay to a signal carrying the output OUT to 0 after the time set if before the end of the set time the input IN returns to 1, the output OUT still generates a pulse signal with this duration: about 3 times the response time plus the delayed time set</p>		<p>Clocking</p> <p>This operator has up to 7 inputs to control the output Duty Cycle. Related to the selected input, this operator will generate a clock with different duty cycle. It can be used, for example, to pass or receive the status information to or from a PLC More info: Clocking operator on page 24</p>

Safety Guard Lock operator

	<p>Guard Lock</p> <p>The Guard lock operator controls locking/unlocking of an electromechanical guard lock by analysing consistency between the Lock command and the status of an E-GATE and a FEEDBACK More info: Guard Lock operator on page 26</p>
---	--

Network operator

	<p>Network</p> <p>Is a serial connection (Loop) of several Mosaic M1 Master unit (with possible expansions). This operator allows stop and reset commands to be distributed in a simply Mosaic network More info: Network operator on page 26</p>
--	--

Counter operator

	<p>Counter</p> <p>Counter operator is a pulse counter that sets output Q to 1 (TRUE) as soon as the desired count is reached. There are 3 operating modes: Automatic, Manual, Automatic + Manual</p>
---	---

Interpage operator

Interpage



The operator Interpage is used to connect parts of the diagram without trace physically the linking. Simply assign the same link identifier operators to Interpage In and Interpage out

Operators Interpage that allow connection of parts of the diagram only by assigning a name to the connection identifier.

[More info: Interpage operators on page 27](#)

Reset operator

Reset M1



This operator resets the Mosaic system in presence of errors on the inputs or outputs

This operator generates a reset of the system when the corresponding input is a double transition OFF-ON-OFF of less than 5s

[More info: Reset M1 operator on page 24](#)

Muting operator objects



L Muting

With 2 Muting sensors for one-way openings (exit only)
Suitable solution for any applications of pallet exit

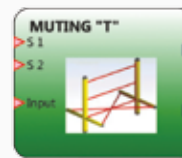

T Muting

With 2 Muting sensors for two-way openings (entry/exit)
Suitable solution for the most common pallet infeed/outfeed applications

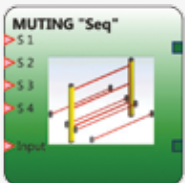

T Muting "Sequential"

With 4 Muting sensors for two-way openings (entry/exit). Suitable solution for transparent material and application with presence of a pallet with reduced width or not centred with respect to the conveyor

[More info: T Muting «Sequential» on page 24](#)

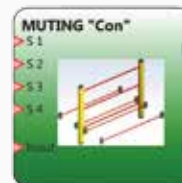

T Muting "Concurrent"

With 4 Muting sensors for two-way openings (entry/exit). Suitable solution for transparent material and application with presence of a pallet with reduced width or not centred with respect to the conveyor

[More info: T Muting «Concurrent» on page 25](#)



Muting Override

Are available two selectable functional mode:
Override with hold to run action
Override with one pulse action

[More info: Muting Override on page 25](#)

INSIGHTS

A DETAILED LOOK INTO THE MOST INTERESTING FEATURES OF MOSAIC

Property window

The property window of each function block allows configuring each block parameters in a simple and easy way.

This allows achieving an important level of customisation for each project tailoring Mosaic behaviour to each particular application.

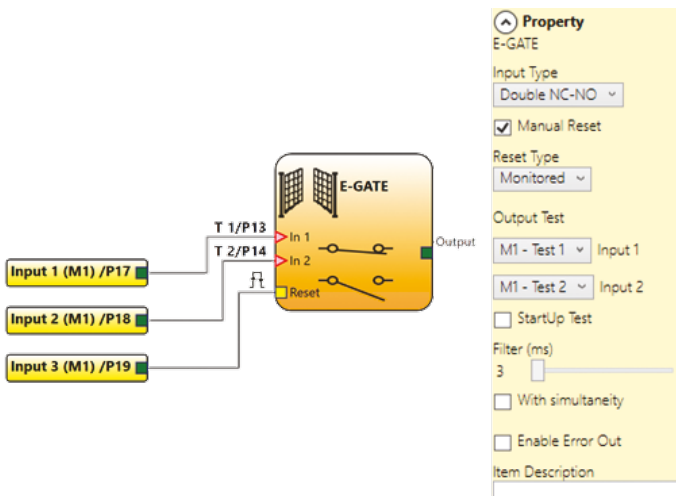

E-gate configuration example

Network_In

This function block creates a network input interface connection, generating on the OUT output a logical level high (1) when the line is high, 0 otherwise.

This input can only be allocated to M1.

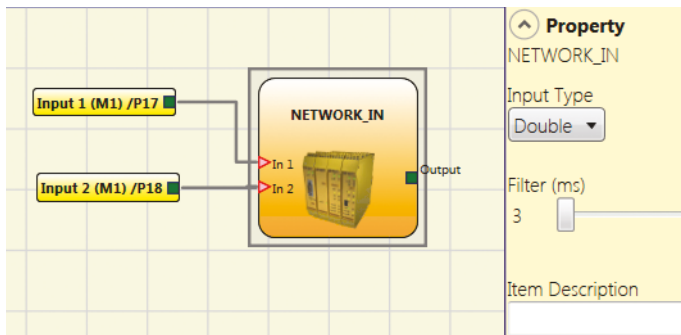

Network_IN Object

They must be physically connected terminals related to an output OSSD or the first Mosaic system status to Network_in inputs of the second Mosaic system.

Automatic or Manual Reset

Manual Reset: if selected this enables the input request to reset each time the area protected by the safety light curtain is occupied. Otherwise (Automatic Reset), enabling of the output directly follows the input conditions.

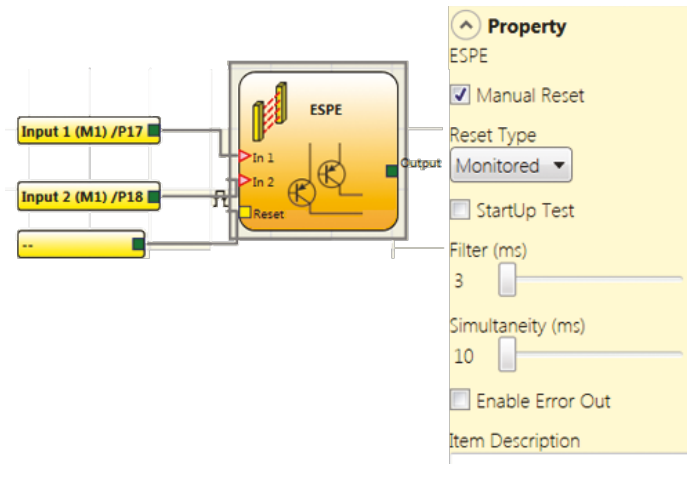

ESPE configuration example

There are two types of reset: Manual and Monitored. When Manual is selected the system only verifies the signal's transition from 0 to 1. If Monitored is selected the double transition from 0 to 1 and then back to 0 is verified.

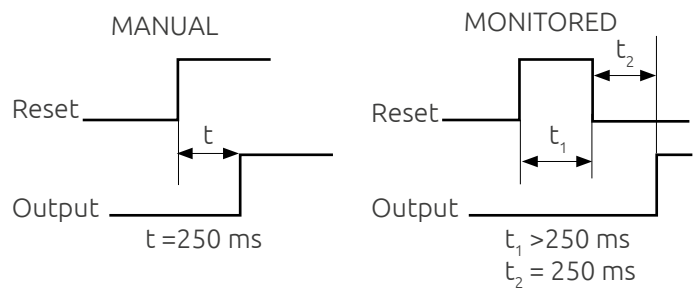

Manual and monitored reset

Reset M1 operator

This operator resets the Mosaic system in presence of errors on the inputs or outputs.

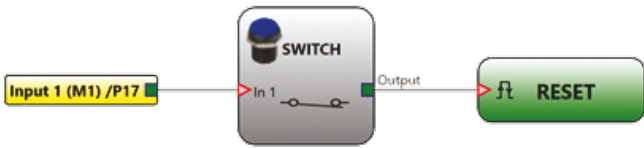

Connection of Reset operator

This operator generates a reset of the system when the corresponding input is a double transition OFF-ON-OFF of less than 5s

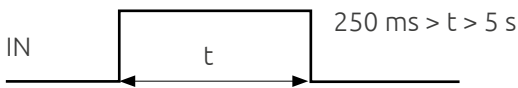

Clocking operator

This operator has up to 7 inputs to control the output Duty Cycle.

Related to the selected input, this operator will generate a clock with different duty cycle.

Clocking operator property

It can be used, for example, to pass or receive the status information to or from a PLC.

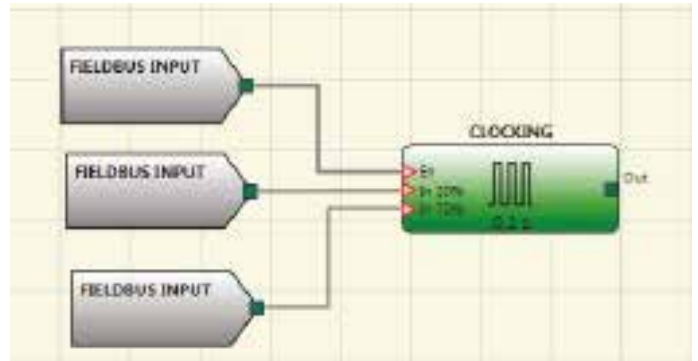

Clocking operator connection sample

T Muting «Sequential»

The activation of the Muting function occurs following sequential interruption of the sensors S1 and S2, subsequently S3 and S4 sensors (without time limit). If the pallet proceeds in the opposite direction the correct sequence is: S4, S3, S2, S1.

Preliminary condition: The Muting cycle can only start if all the sensors are 0 and the inputs are 1 (sensor and light curtain free).

Example of Sequential Muting parameters configuration

Enable only button: It is possible to enable/disable the Muting function depending on the sequence of the machine. This increase the safety.

T Muting «Concurrent»

The activation of the Muting function occurs following interruption of the sensors S1 and S2 beams and then of the sensor S3 and S4: the two sensor must be interrupted within a configurable safety timeout (sensor time) the maximum duration of the Muting status is limited by a timeout.

S1 --X sec. --> S2 ---t---S3 --X sec. --> S4

Where t is a value that depends on the "timeout", X is the "sensor time".

Is available the "Minimum sensors time option" that allows you to stop the Muting function if the passage in front of the sensors 1-2 and 3-4 takes place with a time less than 150 ms. In this way it is possible to detect the transit of a person much faster than a pallet.

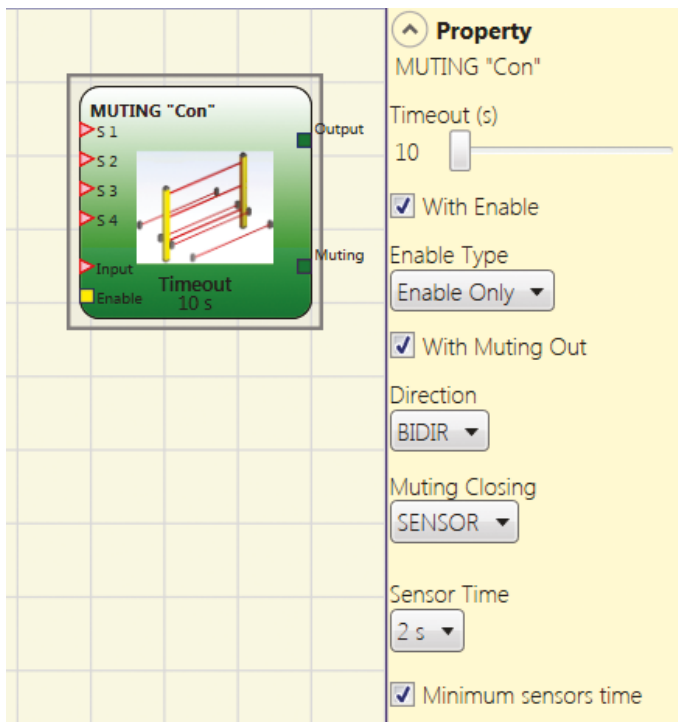

Example of Sequential Muting parameters configuration

Muting closing button: It is possible to use the light curtain as sensor and anticipate the Muting closure the moment the light curtain is free instead waiting the third Muting sensor.

Muting Override

This function allows you to locally restore the safety function of the light curtain after an engaged of the light curtain not related to a normal Muting sequence.

There are also the following signalling outputs:

- Request = need to override
- OverOut = override active

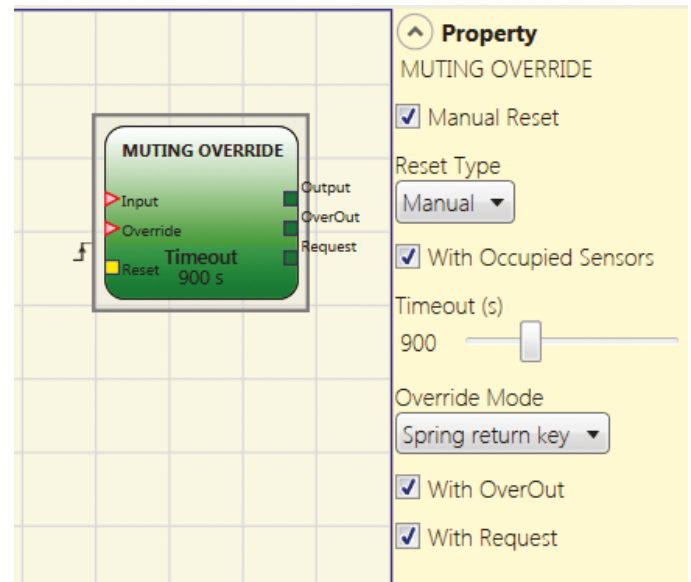

Example of Muting override configuration

Guard Lock operator

The Gate input is connected to the functional block e-gate. This is an example of Guard Lock configuration.

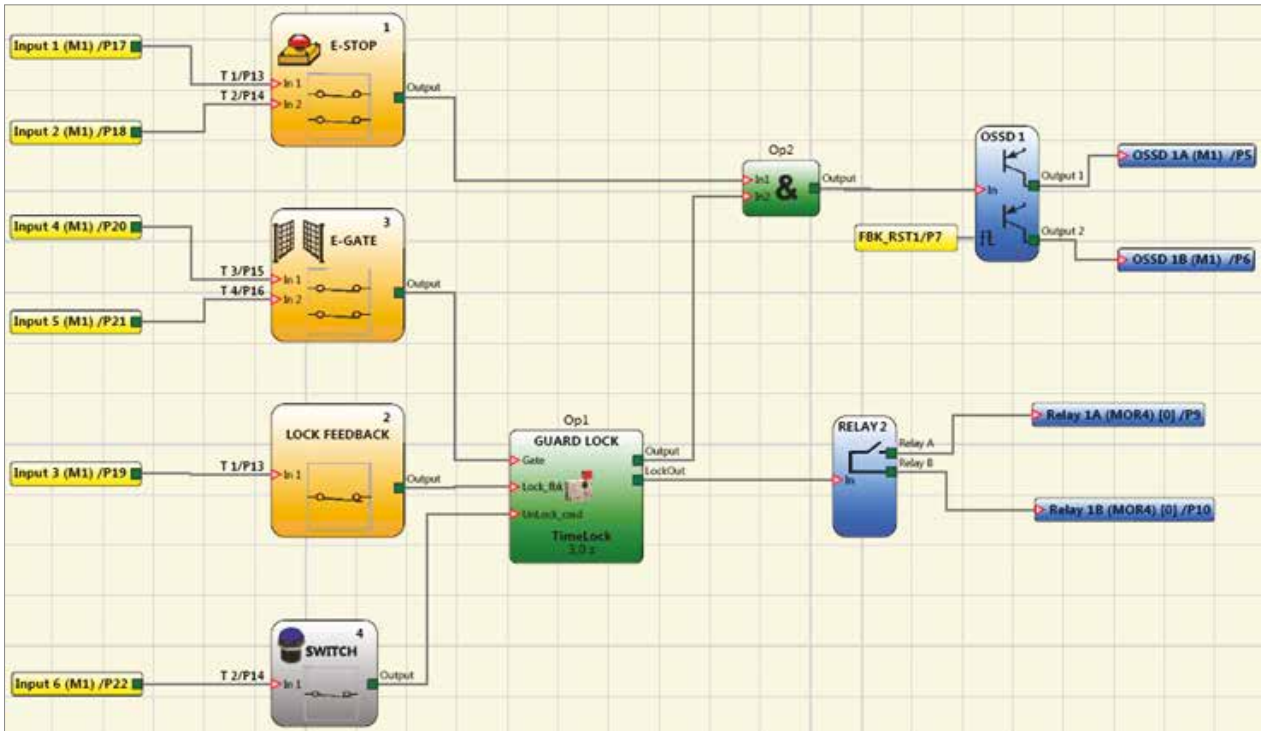

Sample of Guard Lock operator connection

1. The Lock_fbk input is connected to the functional block Lock_fbk (feedback from the lock)
2. The UnLock_cmd input (unlocks command) is connected to an input switch
3. The signal output will be 1 if the door is closed and the guard lock is locked
4. When an unlock command is applied to the input (UnLock_cmd), the output signal will be set to "0" and after a programmable time Time_Lock (2 sec. in the example) the guard lock is unlocked through the LockOut output

Network operator

It allows loop connection (Loop) of several Mosaic M1 Master unit (with possible expansions). This operator allows stop and reset commands to be distributed in the Mosaic network.

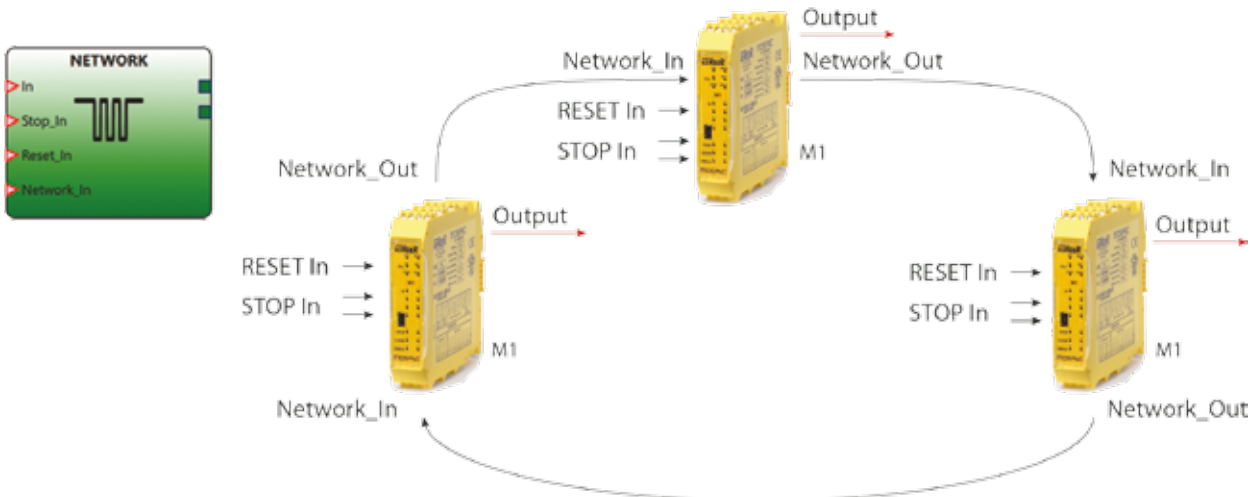

Network connection

Speed monitoring object configuration example

Example of speed monitoring of one axis. Monitoring of stand still and speed control with selectable 2 thresholds

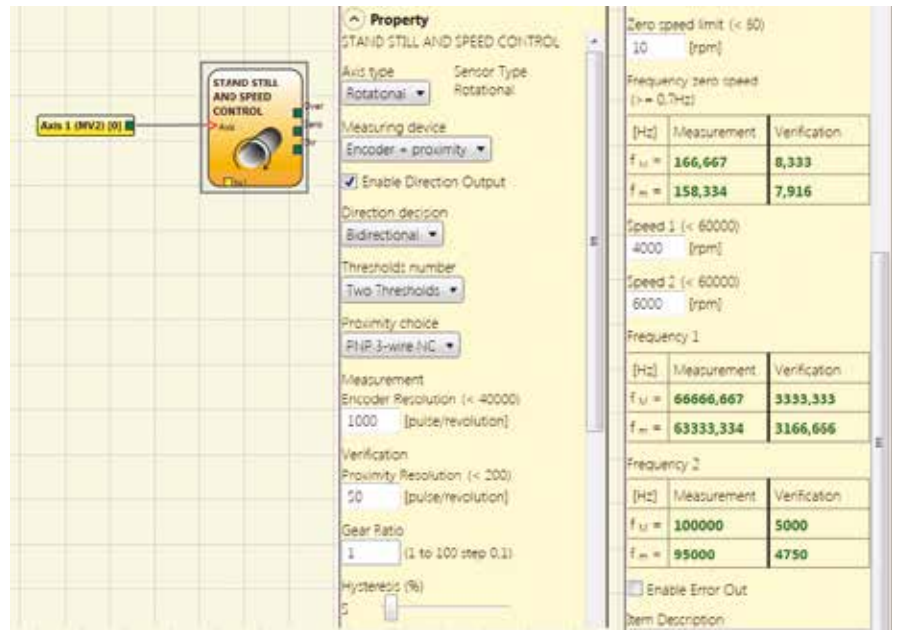

Speed monitoring object configuration example

Interpage operators

Interpage operators is a label assigning a name to a certain logical interconnection.

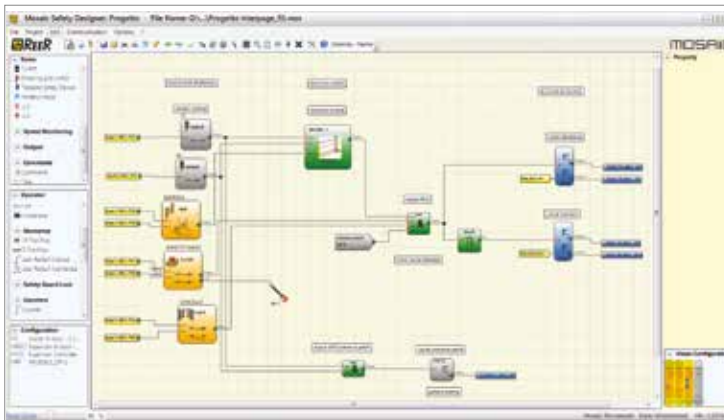
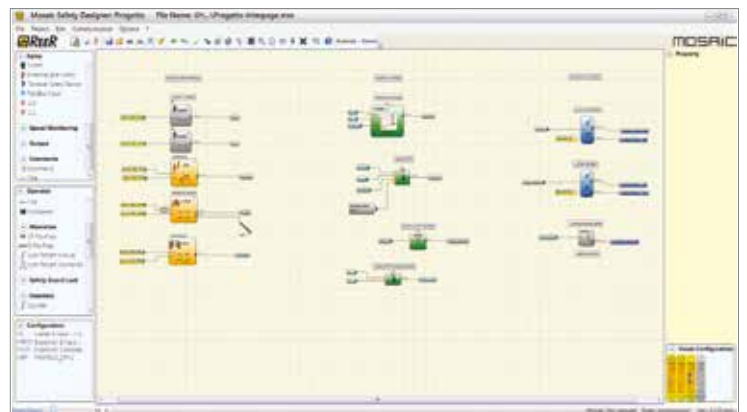
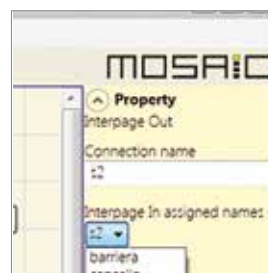

Diagram with wires

Considerable simplification and readability of the diagram.

To simplify the names assignment a drop-down menu, that lets you choose the name of the "Interpage out" among those assigned to the operators "Interpage In"



The same diagram with Interpage function applied

Interpage operator advantages

REAL TIME MONITOR

The I/O MONITOR allows the real-time monitoring of all the I/Os of a Mosaic system and the diagnostic information about a working system.

VISUALIZATION

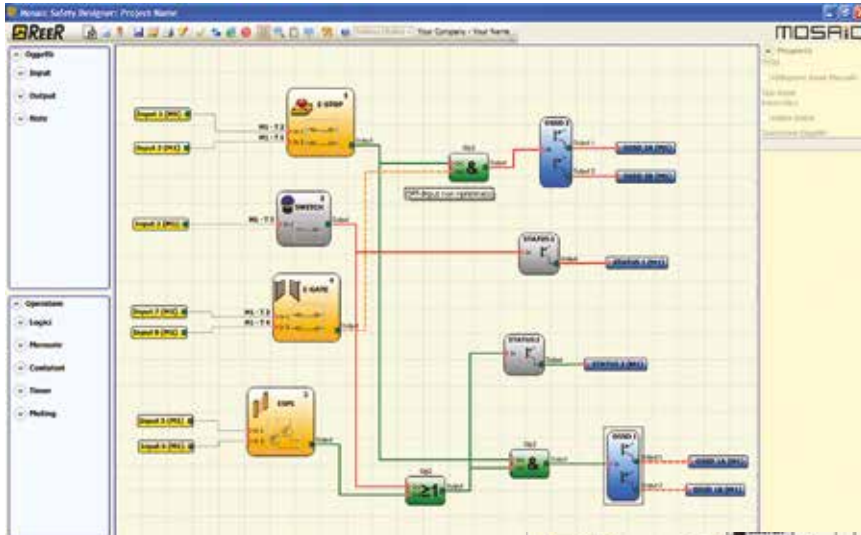

Graphic visualization

Module	Block	Type	I/P/UT	State	Diagnostic engine	Module	OSCO	State	Diagnostic	Module	Status	State	Out Test	Diagnostic Out Test
M1	1	E-Stop	IN1	ON		M1	OS501	ON		M1	STATUS1	OFF	M1 T1	
M1	2	Switch	IN2	OFF		M1	OS502	OFF		M1	STATUS2	ON	M1 T2	
M1	3	ESPE	IN6	ON									M1 T3	
M1	4	E-Gate	IN7	OFF									M1 T4	

Text visualization

Real time Monitor

SIMULATION FUNCTION

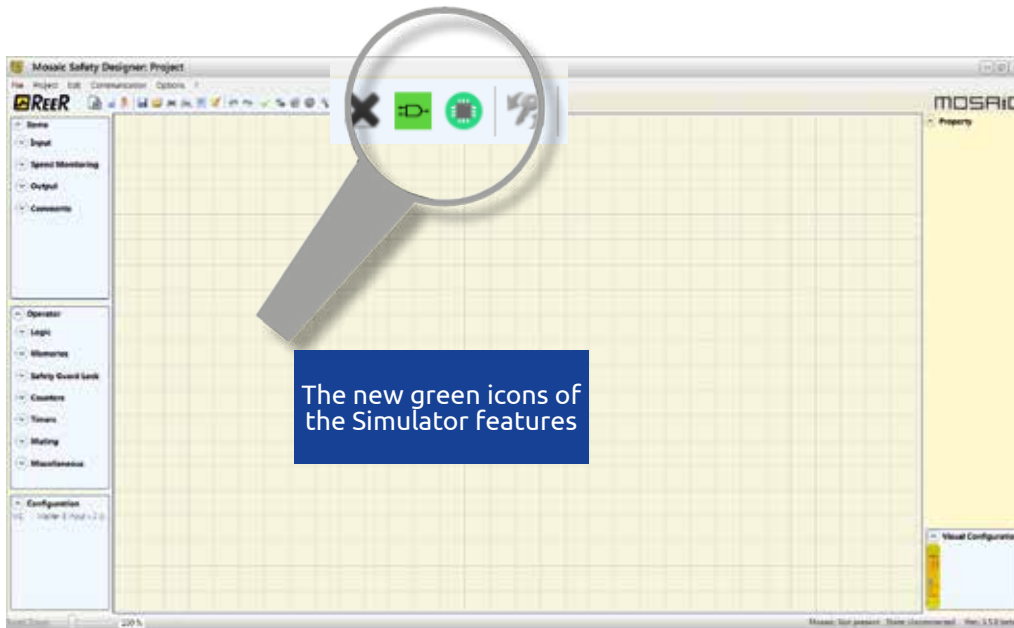

The Simulator allows to verify the functionality and correct operations of a project created with MSD before the assembly of the machinery.

It allows activate the inputs of the system manually or in a programmed way in order to ensure the outputs gained are correct.



Schematic simulation



Managing graphic simulation

NOTE: the simulation feature is available with MSD version 1.5 and M1 firmware version 3.0 or higher.

SCHEMATIC SIMULATION

The schematic simulation allows to “start” the project via a dedicated menu and to operate directly on any of the inputs to verify the logic of the system.

Simulation can start, stop or restart via dedicated menu

Timings setting
When timer operators are included in the actual configuration.

Clicking on the button on the lower right of each input block it is possible to toggle its output status.

Likewise in the monitor function, also in this case the color of the line indicates the signal status: green means the signal is at LL1, red means the signal is at LL0

MANAGING GRAPHIC SIMULATION

The graphic simulation allows to load a number of programmed inputs status change and to verify the logic of the system as a graphical output diagram. This methodology allows to create templates replicating the exact functionality of a machinery and apply them on different projects.

Template Stimuli

Based on the schematic loaded, it creates a template file to fill with the desired values.

The user can modify the status of the input signals in a certain time.

Parameter Editor

The user must save the file with the required name and open it again with a text editor to modify the parameters.

Simulation with Stimuli

Load the template file saved and starts the simulation.

```

prova5 - Blocco note
File Modifica Formato Visualizza ?

// E-Stop
Input6
0:0
500:1
1000:0
1500:1

// OSSD
Fbk_rst1
0:0
500:1
1000:0
1500:1

// OSSD
Fbk_rst2
0:0
500:1
1000:0
1500:1

// OSSD
Fbk_rst3
0:0
500:1
    
```

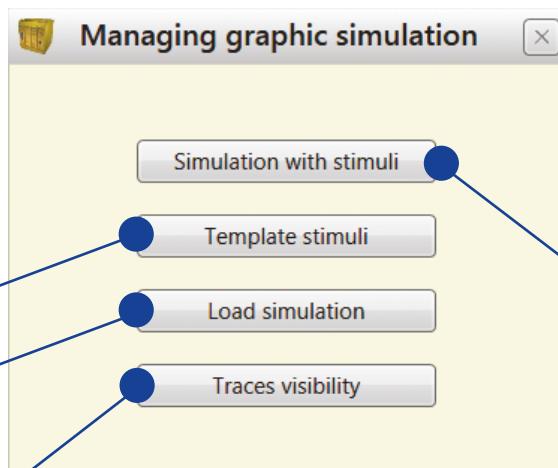

```

prova5 - Blocco note
File Modifica Formato Visualizza ?

// E-Stop
Input6
0:0
500:1
1000:0
1500:1

// OSSD
Fbk_rst1
0:0
500:1
1000:0
1500:1

// OSSD
Fbk_rst2
0:0
500:1
1000:0
1500:1

// OSSD
Fbk_rst3
0:0
500:1
    
```

Load simulation

With this feature is it possible to load a previous completed simulation.

Traces visibility

With this option the user could select the traces (waveform signal) to be displayed in the graph or not.

At the end of the simulation a graph with all the resulting signals is showed.

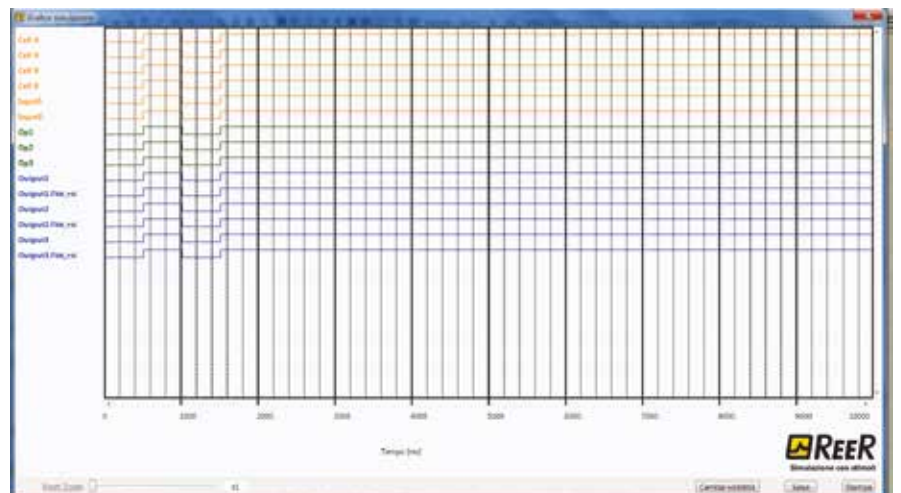

HSD SOFTWARE

MESSAGES EDITOR FOR HM1 DISPLAY

HSD is the editor software that allows programming of the device HM1

HM1 can be connected to Mosaic system in 3 ways:

1. Wired to a status output connected to the serial operator, asynchronous serial connection. Max 32 status displayed. See picture 1
2. Wired to 2 status outputs connected to the serial operator, synchronous serial connection. Max 16 status displayed. See picture 2
3. Wired to the serial MBx module via RS 485 serial port, All I/O statuses and diagnostic displayed

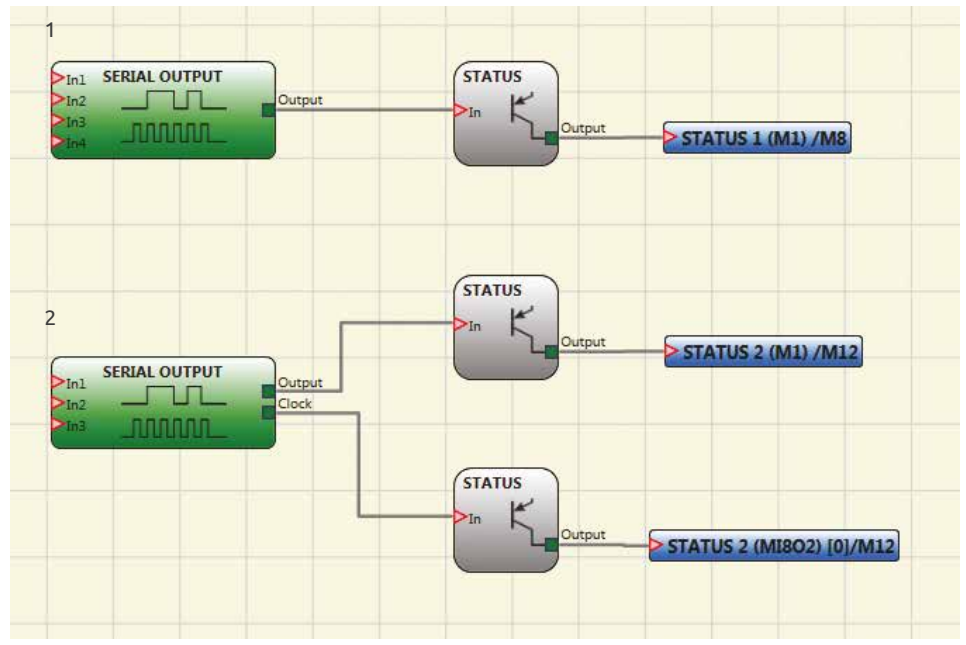

HM1 connections type

The digital signals from the output status or serial can be converted to display messages on the display HM1 through this HSD editor software.

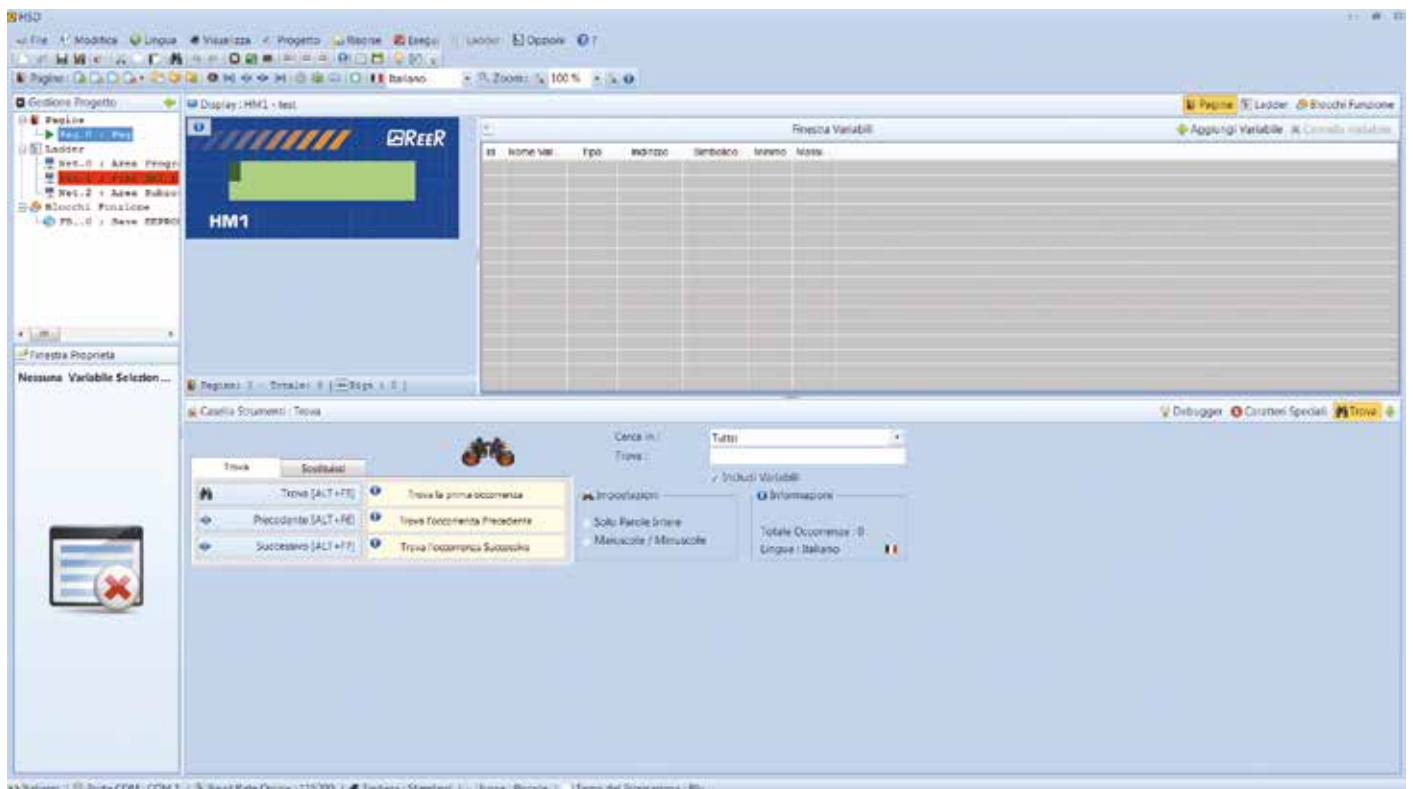

HSD main screen

APPLICATION EXAMPLES

SAFETY MANAGEMENT OF A PALLETIZING SYSTEM WITH TWO ROBOTIC CELLS

The system comprises a conveyor that transports boxes to two robotic palletization cells.

The machine is completely protected by a fence with three access gates (one for each robotic cell and one for the conveyor area) equipped with a safety switch. When the gate of the robotic cell is open, the corresponding robot stops. When the conveyor area gate is open the entire plant stops.

The completed pallets are collected by a forklift truck through the access gate which is protected by a safety light curtain. The access of the forklift truck for collecting the pallet, when the robot is stopped in the rest position, by reason of the safety light curtains, prevents the robot to start.

In all other phases of processing, occupation of each light curtain causes the related robot to stop. The related manual restart control is located close to each light curtain. The system is equipped with four emergency push buttons (e-stop).

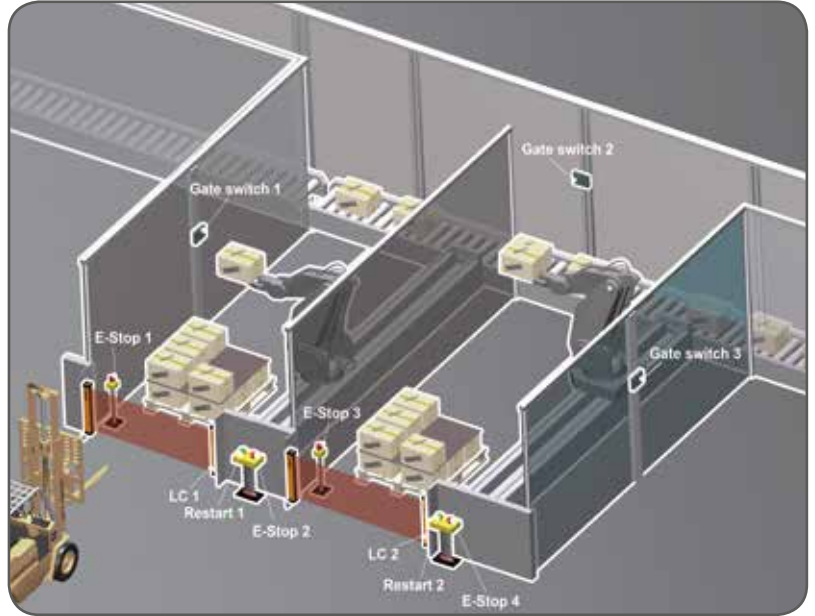

Total safety devices: 2 safety light curtains, 2 restart buttons for the safety light curtains, 3 safety gate switches, 4 emergency push buttons.

Using conventional components – safety relay modules – to build up the safety circuit, it would be necessary to use at least six safety modules, wired to each other in order to perform the required functions: 2 safety relays for the light curtains, 3 safety relays for the gate switches, 1 safety relay for the emergency stop chain.

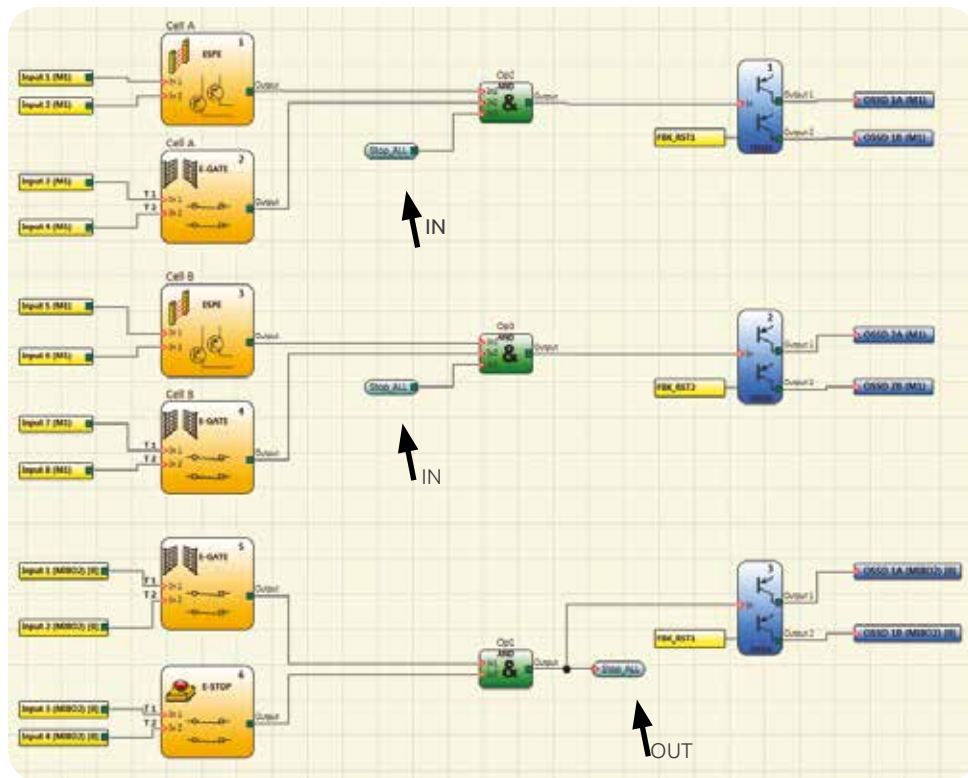

16 inputs - 4 OSSD pairs - 8 test outputs - 4 signal outputs

Solution with Mosaic

Using Mosaic to build up the safety circuit, it is sufficient to use:

- 1 M1 Master unit
- 1 MI8O2 expansion unit

Note 1: the Reset buttons are not displayed on the diagram because they are directly connected to the feedback of the OSSD safety outputs (inputs FBK_RST1, FBK_RST2). The 4 E-STOP are connected in series and in the diagram they are represented with a single block.

Note 2: 3 operators Interpage (2 In and 1 Out) were included in the diagram. These allow you to link the inputs and outputs of the logic gates "&" without having to draw the line.

SAFETY MANAGEMENT OF A MACHINING CENTRE WITH ALTERNATE LOAD / UNLOAD

The operator is required to load and unload the workpiece. The machine is protected by two horizontal safety light curtains. In this case, each light curtain must be equipped with the Muting function so as to permit access to the hazardous area by personnel during the non-hazardous part of the machine cycle.

Depending on the position of the tool, which is the hazardous element, one of the two light curtains (the one facing the tool working area) is active, while the other is muted so that the operator can load/unload the workpiece.

The Muting condition of the two safety light curtains will then be inverted when the tool is required to operate on the opposite side of the machine.

The machine is completely protected by a fence with an access gate equipped with a safety switch. When the gate is opened, the machine stops. The related manual restart control is located close to each safety light curtain. The system is equipped with three emergency push buttons which, if activated, stop the machine.

Total safety components: 2 safety light curtains, 2 restart buttons for the safety light curtains, 1 safety gate switch, 3 emergency push buttons.

Using conventional components – safety relay modules – to build up the safety circuit, four safety modules would be necessary: 2 safety modules for the safety light curtains with Muting function, 1 safety module for the gate switch, 1 safety module for the emergency stop.

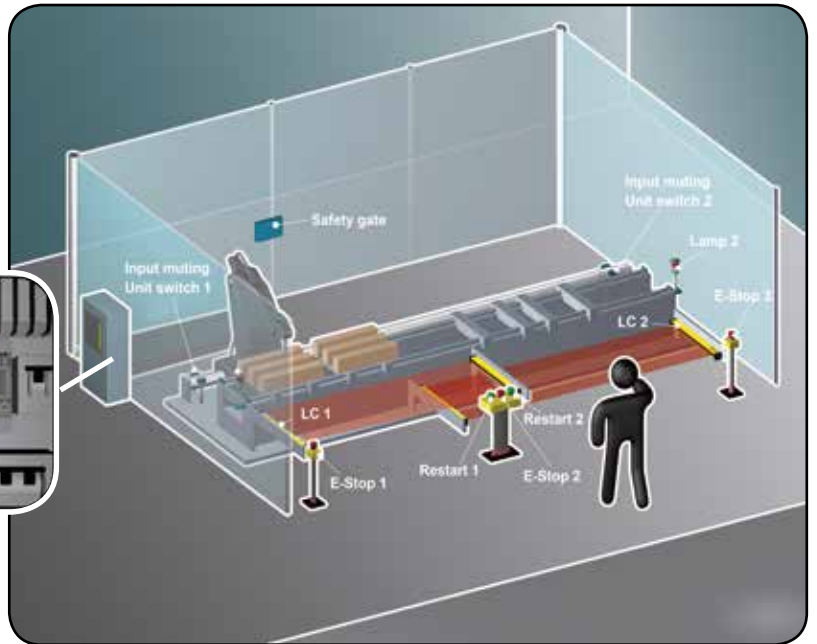

Solution with Mosaic

Using Mosaic to build up the safety circuit, it is sufficient to use:

- 1 M1 Master unit
- 1 MI8 expansion unit

NOTE: the Reset buttons are not displayed on the diagram because they are directly connected to the feedback of the OSSD safety outputs (inputs FBK_RST1, FBK_RST2).

The 3 E-STOP are connected in series and are represented in the diagram with a single block.

The diagram also shows 2 status outputs used to drive the indication lights of the active Muting.

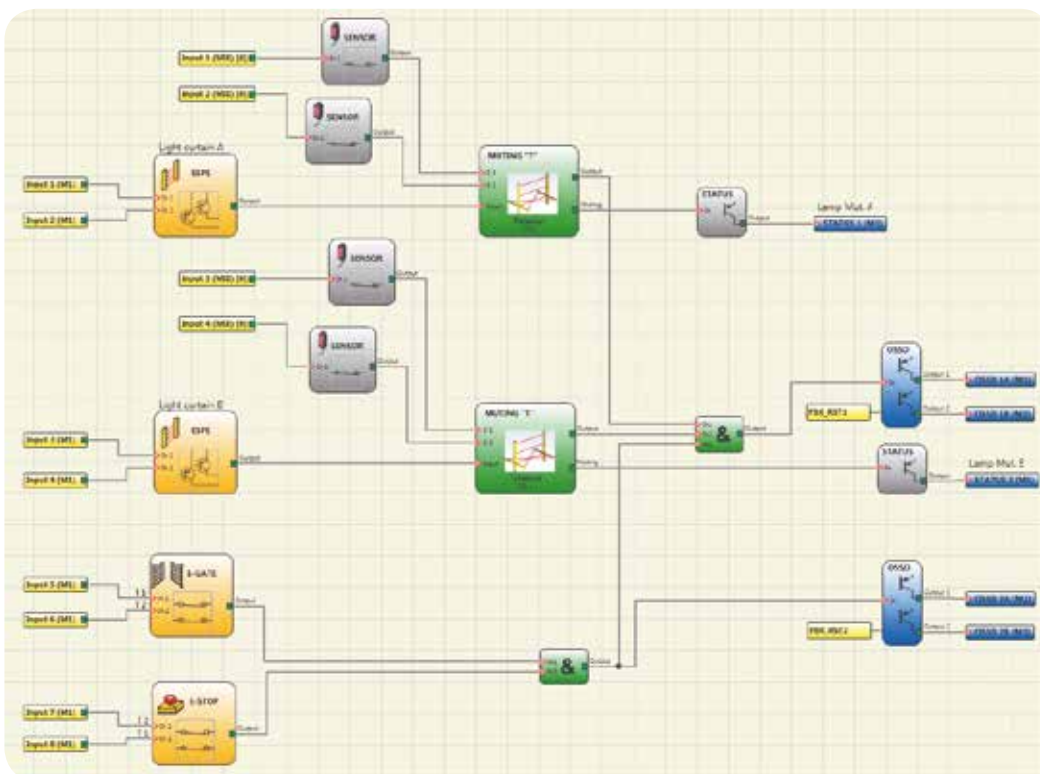

16 inputs - 2 OSSD pairs - 8 test outputs - 2 signal outputs

SPEED MONITORING FOR A HAZARDOUS TOOL

In this example, to place or remove tooling or to perform maintenance activity where it is necessary for the operator to enter the dangerous area.

As long as the tool is working at the normal speed the GUARD LOCK is locked and the access to the hazardous area is not allowed.

Access to the hazardous area is allowed either when the working cycle is over or when the operator switches the MOD SEL to "Access Request". When the tool stops the lock is unlocked and allows the opening of the door. In this case the speed controller verifies that the tool is stopped (zero speed).

For maintenance, it is necessary that the system operates at reduced speed. The operator will have to act on the selector (MOD-SEL) and bring it in the "Maintenance" position. When the tool stops the lock is unlocked and allows the door opening. If the tool has to be kept moving for maintenance reasons as the operator is inside the hazardous area, this is possible through the Grip Switch. The speed monitoring device detects whether the speed of the tool is under a defined threshold set through the MSD. If the threshold is exceeded or the Grip Switch is released the machine is immediately stopped.

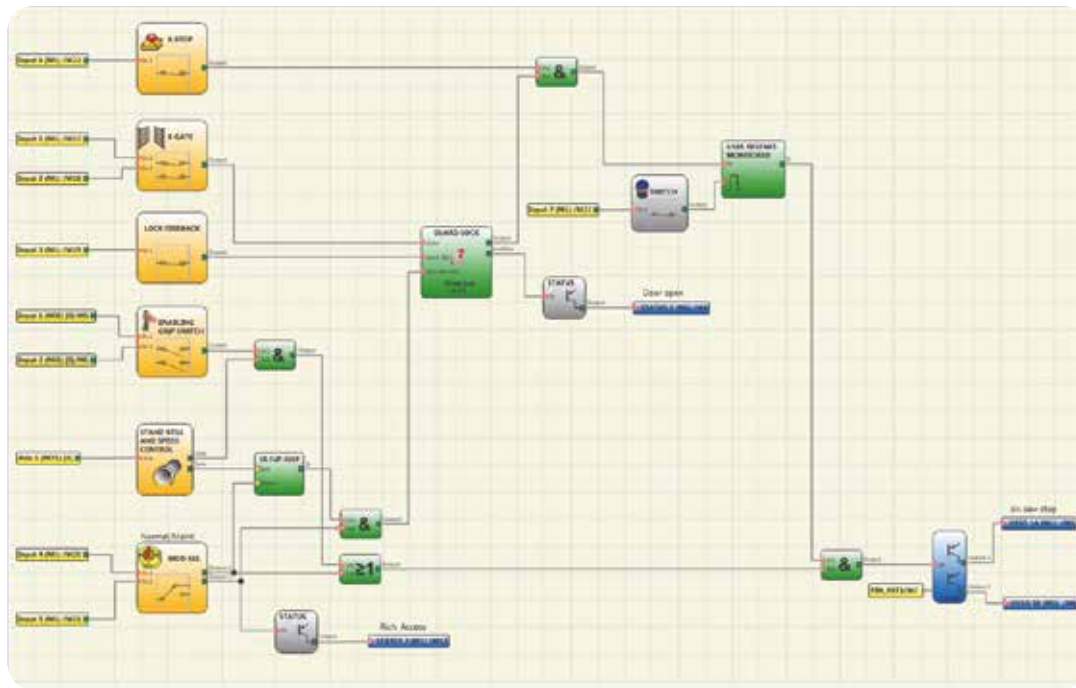
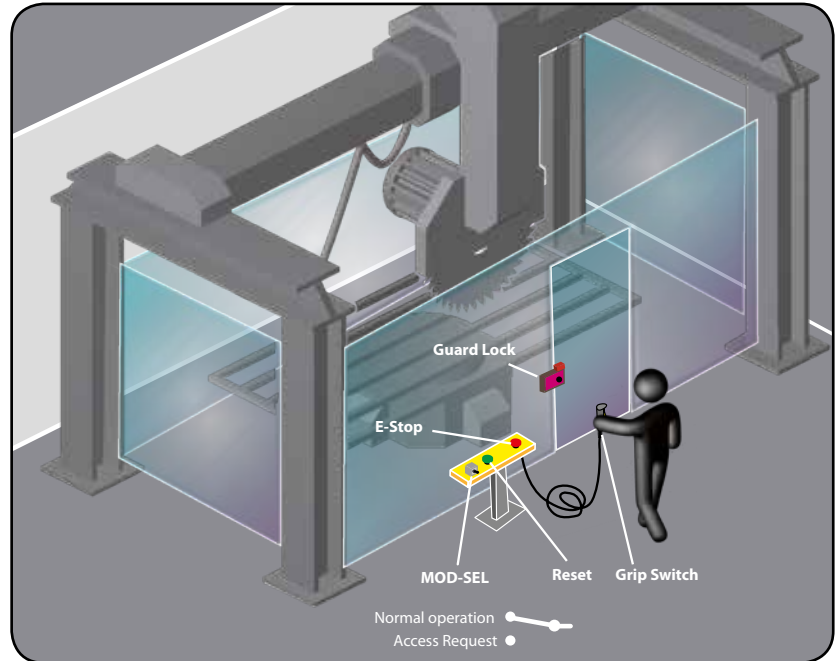

On the operator panel are available the emergency stop (e-stop) button and reset button to restore the normal operating conditions of the safety lock after the operator intervention.

Using Mosaic to build up the safety circuit, it is sufficient to use:

- 1 M1 Master unit
- 1 MI6 expansion unit
- 1 MV0 expansion unit for safety speed monitoring

Speed monitoring

Comments

Using Mosaic, all the safety logic circuitry is implemented using the graphic interface and not by hard-wiring the outputs of the relay modules to each other. Correct functioning of the logic circuitry is checked during the design phase by the **validation function** and can be tested with the **simulation** and **monitor function** during installation. During the design phase, safety functions can be easily added or removed, for example adding other sensors or zones. Start up tests can be inserted in order to detect any attempt of by-passing the safety system, which is always a possibility with traditional relay modules.

TYPICAL APPLICATIONS

Pallets
production
machinesWood-working
machinesPainting machines for
wood-working
industryHandling
machines for
wood-working
plantsWood-working
machines
squaring
edgebanders

Robots

Plastic film
production
machinesAGVs
(Automatic
Guided
Vehicle)Pad printing
machinesBending
machines

Palletising systems



Palletising and bottling plants



Palletising systems



Crate packer/unpacker and palletising systems



Beam drilling and sawing machines



Panel sizing saws



Vertical lift storage system



Rail dependent storage and retrieval equipment



Industrial boilers



Industrial thermal processes





At ReeR we put our Customers always first

ReeR after sales service is committed to support all customers that need technical guidance regarding functionality, handling and installation of our products.

Customer Service Hotline

+39 011 24 82 215

Monday to Friday 8.30 - 12.30 and 13.30-18.00 (CET)

or contact

aftersales@reer.it

For product returns please visit www.reersafety.com for further information.

Safety. Detection. Control.



ReeR SpA

Via Carcano, 32

10153 Torino

Italy

T +39 011 248 2215

F +39 011 859 867

www.reersafety.com | info@reer.it



More than 50 years of quality and innovation

Founded in Turin (Italy) in 1959, ReeR distinguished itself for its strong commitment to innovation and technology.

A steady growth throughout the years allowed ReeR to become a point of reference in the safety automation industry at a worldwide level.

The Safety Division is in fact today a world leader in the development and manufacturing of safety optoelectronic sensors and controllers.

ReeR is ISO 9001, ISO 14001 and BS OHSAS 18001 certified.



Issue 1

Rev. 1.0
June 2017
8946225
Printed in Italy

Mosaic Catalog English



ReeR SpA does not guarantee that product information in this catalogue are the most current available. ReeR SpA reserves the right to make changes to the products described without notice and assumes no liability as a result of their use or application. Our goal is to keep the information on this catalogue timely and accurate, however ReeR SpA accepts no responsibility or liability whatsoever with regard to the information on this catalogue. Reproduction is not authorised, except with the expressed permission of ReeR SpA.